

## EBU Technical Recommendation R81-2000 Recommended minimum information and preferred format for labels on television recordings for the international exchange of programmes

<i>EBU Committee</i>	<i>First Issued</i>	<i>Revised</i>	<i>Re-issued</i>
PMC	1995	2000	

**Keywords:** Video recording - General

The EBU *recommends* the following procedure for the labeling of video tapes and other broadcast media used for the international exchange of television programmes.

The labeling should consist of three elements:

- A tape or spool number label with bar-code, identifying the spool uniquely, but not containing any programme information.
- A programme label identifying the programme and the most important features of the recording.
- A record report, containing full details of the technical parameters of the recording.

### 1. Spool number label

The spool label is generated by the facility which first uses the blank stock and may be affixed before any recording is made as a means of stock control. The label should conform to the requirements of the International Broadcast Tape Number (IBTN) scheme [1]. The bar-code form of the label may be read by any organization participating in the IBTN scheme. The label can also be read normally.

*Fig. 1* shows examples of spool labels for cassettes and open reel tapes.

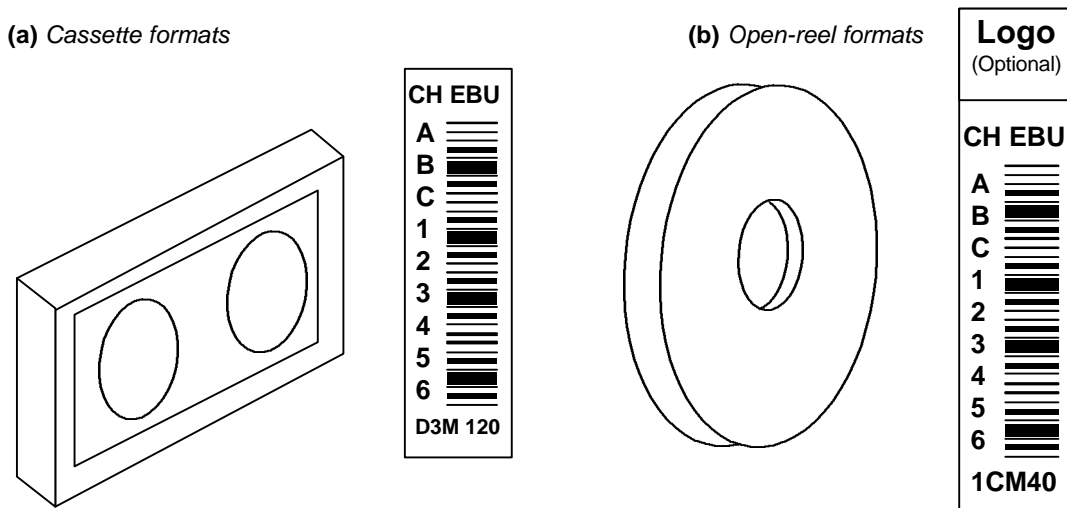

**Fig. 1 – Examples of cassette and spool labels**

Two identical spool number labels are needed: one for the shipping container and one for the spool or cassette itself, so as to ensure that the cassette can reliably be replaced in the correct container.

It is recommended that the cassette label is not fixed to the front face of the cassette since this space may be used for machine-specific labels used with automatic-loading machines.



### 3. Record report

A record report containing details of the recording should be included with the recording. An example of a record report is given in Fig. 3. A similar report form can also be used to:

- state preferences/requirements for exchange;
- provide advance information by post/fax.

A completed example of a report form is shown in the Appendix.



**RECORD  
REPORT**

European Broadcasting Union      Union Européenne de Radio-Télévision  
Case Postale 67 CH-1218 Grand-Saconnex GE Switzerland / Suisse Tel: +41 22 717 21 11

Main Title: \_\_\_\_\_  
Episode Title / No: \_\_\_\_\_  
Reel: \_\_\_\_\_ of: \_\_\_\_\_ Next Reel No: \_\_\_\_\_

Prog No: \_\_\_\_\_  
Tape No: \_\_\_\_\_

Language: \_\_\_\_\_  
Mono  Stereo   
Dolby A  Dolby C  Surrnd   
  
Line-up \_\_\_\_\_  
Track 1 \_\_\_\_\_  
Track 2 \_\_\_\_\_  
Track 3 \_\_\_\_\_  
Track 4 \_\_\_\_\_

Tape format: \_\_\_\_\_ 625  525  PAL  SECAM  NTSC  YUV   
Time code continuous YES  NO  VITC YES  NO   
Aspect Ratio: \_\_\_\_\_ Squeezed  Letterbox  Centred  Shifted   
Subtitles: on disc  on tape  EBU  NCI  Text Page No \_\_\_\_\_  
Colour Bars: 100%  EBU  SMPTE  Countdown Clock YES  NO   
Notes: \_\_\_\_\_

Technical Comments

Operator: \_\_\_\_\_ Date: \_\_\_\_\_

PARTS	START	END	Duration
Line-up			
Clock			
Part 1			
Part 2			
Part 3			
Part 4			
Part 5			
Part 6			
Total Duration of Programme: _____			

FOLD

175.0  
mm

150.0 mm

**Fig. 3 – Recording report form**

The EBU is aware that concern has been expressed about the possibility that the chemicals in some paper used for record reports may affect the tape and the life of the recording in storage. The EBU is currently investigating the matter in depth; in the meantime, it may be advisable in long-term archives to store the paper record report in a separate wallet on the outside of the tape case.

## Appendix Examples of completed labels and report

This Appendix gives examples of a completed record report form and typical programme labels.



**RECORD  
REPORT**

European Broadcasting Union  
Case Postale 67 CH-1218 Grand-Saconnex GE Switzerland / Suisse Tel: +41 22 717 21 11

Union Européenne de Radio-Télévision

Main Title: White Jazz

Episode Title / No: \_\_\_\_\_

Reel: 1 of: 1 Next Reel No: \_\_\_\_\_

Prog No: 20322

Tape No: ABC123456

Language: English

Mono  Stereo

Dolby A  Dolby C  Surrd

Line-up 1 kHz + 0.5 dB

Track 1 TX - Left

Track 2 TX - Right

Track 3 M & E - Left

Track 4 M & E - Right

Tape format: D3M 625  525  PAL  SECAM  NTSC  YUV

Time code continuous YES  NO  VITC YES  NO

Aspect Ratio: 16:9 Squeezed  Letterbox  Centred  Shifted

Subtitles: on disc  on tape  EBU  NCI  Text Page No 888

Colour Bars: 100%  EBU  SMPTE  Countdown Clock YES  NO

Notes: Programme example by courtesy of Channel 4 Television,  
London

Technical Comments

*Some film grain on Super 8 film insert  
at 12' 15"*

*- Otherwise Satis*

Operator: PM Date: 8 Jan '95

PARTS	START	END	Duration
Line-up	0..00	02..00	
Clock	02..00	03..00	
Part 1	03..00	25.47	22..47
Part 2	27..00	43..23	16..23
Part 3	44..00	56..44	17..44
Part 4			
Part 5			
Part 6			
Total Duration of Programme:			<u>52..00</u>

FOLD

150.0 mm

175.0 mm

 EBU UER	<b>European Broadcasting Union      Union Européenne de Radio-Télévision</b> Case Postale 67    CH-1218 Grand-Saconnex GE    Switzerland/Suisse Tel: +41 22 717 21 11	
	Title: <hr/> WHITE <hr/> JAZZ <hr/> <hr/> <hr/> Reel <u>1</u> of <u>1</u> Date: <u>8 Jan '95</u>	Title: <u>White Jazz</u> <hr/> Episode title / No: <u>~</u> <hr/> Programme No: <u>20322</u> ■ Reel <u>1</u> of <u>1</u> <hr/> Soundtrack language: _____      ■ Mono <input type="checkbox"/> Stereo <input checked="" type="checkbox"/> <hr/> ■ 625 <input checked="" type="checkbox"/> 525 <input type="checkbox"/> ■ YUV <input checked="" type="checkbox"/> PAL <input type="checkbox"/> SECAM <input type="checkbox"/> NTSC <input type="checkbox"/> <hr/> ■ Complete <input checked="" type="checkbox"/> Needs Post production <input type="checkbox"/> ■ Continuous <input type="checkbox"/> In parts <input checked="" type="checkbox"/> <hr/> ■ 4 x 3 <input type="checkbox"/> 16 x 9 <input checked="" type="checkbox"/> Letterbox <input type="checkbox"/> ■ Dolby C <input type="checkbox"/> Non-Dolby <input checked="" type="checkbox"/>

Title .....	Eurovision Song Contest 1992.....	✓	625 <input type="checkbox"/>
			525 <input type="checkbox"/>
Episode title / No.:	.....1.....	4:3 <input checked="" type="checkbox"/>	16:9 <input type="checkbox"/> Letter-box <input type="checkbox"/>
Sound-track language: .....	English.....	✓ Mono <input type="checkbox"/>	Stereo <input type="checkbox"/> PAL <input type="checkbox"/>
		SECAM <input type="checkbox"/>	NTSC <input type="checkbox"/>
Complete <input type="checkbox"/>	Needs post production <input checked="" type="checkbox"/>	Continuous <input type="checkbox"/>	In parts <input type="checkbox"/> Dolby C <input type="checkbox"/> Non-Dolby <input checked="" type="checkbox"/>

### Bibliography

- [1] EBU document Tech. 3279 (1995): **International Broadcast Tape Number (IBTN) and bar-code labels**
  - See also:
  - [2] EBU Technical Recommendation R49-1993: **Tape alignment leader for the exchange of television programmes**
  - [3] EBU Technical Recommendation R71-1992: **Labelling and identification of 16:9 aspect ratio television tape-recordings**
  - [4] EBU Technical Standard N6-1994: **Helical-scan television recording on 25.4-mm tape**
-