



EBU Technical Review

January 2009

The Super Hi-Vision demos at IBC-2008

The reproduction of articles in EBU Technical Review is authorized only with the prior consent of the Editor-in-Chief.

The responsibility for views expressed in EBU Technical Review rests solely with the authors.

Editeur Responsable: Lieven Vermaele
Editor-in-Chief: Mike Meyer
E-mail: tech_review@ebu.ch



EBU Technical Review

Editorial

Edition: January 2009

Beyond HDTV – television ‘on the run’?

When is enough, enough? Surely the paint is barely dry on the signposts to HDTV? Why spend time and money looking beyond that? It will confuse the public – and quite possibly broadcast management as well. These days, surely technology evolution is in ‘dog years’. So come on, let’s start when we really need something. And by the way, did you hear about the economic downturn?

The answer to the why of ‘beyond HDTV’ lies in the very, very long lead times that new television systems fundamentally need. The answer lies in making the distinction between what we might call ‘long-run’ and ‘short-run’ new systems.

The Internet is a fantastic vehicle for introducing new systems, because there is no new infrastructure needed, either for the provider or the user. We already have PCs and the Internet itself. All you need is to download software. These are ‘short-run’ new systems.

Although not a black-and-white distinction, we also need to look beyond the short-run, to systems which do need investments by the provider and user, and new delivery infrastructures. This is the ‘long-run’. It is in this category that ‘beyond HDTV’ lies.

Any sensible person looks both to the short-run and the long-run – and understands the distinction. We should do the same, because there is always a ‘long-run’.

Today, in 2009, there are about 100 HDTV channels in Europe. But, the founding father of HDTV, Dr Fujio, had the idea for HDTV during the Tokyo Olympic Games of 1964. He thought the public should have a way of feeling they were virtually present on such great occasions. He was right, and we do.

The first HDTV broadcasts (in the 1125i/60 format) were as long ago as 1984 in Japan – over twenty years ago. So, the time taken from conception of the idea to rollout of services has been, for us in Europe, over forty years. Could anyone doubt that, on this evidence, it is reasonable for us to start now looking ahead to the next step beyond HDTV?

The tests done in 2008 using the NHK Super Hi-Vision (SHV) technology were important and useful in many ways, and much of the background is given in the three articles published in this special edition of EBU Technical Review.

One aim was to test the broadcast potential of SHV in the 22 GHz band. In the early 1990s, broadcasters had asked for (and were granted) some spectrum in this band – to be used for high-bitrate HDTV broadcasting – but, until now, they had not used it. For the IBC-2008 demos, transmission tests – between Turin and Amsterdam – were carried out in this frequency band at a compressed bitrate of about 120 Mbit/s.

The laboratories also tested transmission – between London and Amsterdam – over an ultra-wide-band IP connection at about 600 Mbit/s.

There were a number of firsts in these tests, including the first live international interview using SHV, and the first international 22 GHz satellite distribution. It was a privilege to work in an amazingly efficient and effective team.

But this was just the beginning of the study of 'TV beyond HDTV', and not by any means the end. Clearly the future of television will involve a greater sense of reality in the viewing experience. But how will this be most effectively achieved? Is it purely a matter of more definition per picture, or would a better balance be achieved with greater temporal resolution? Where, if anywhere, does stereoscopic television fit in? Where overall, does the best balance of improvements to the picture elements lie? This is a really fascinating question for the scientist in us all. It must of course be weighed up by balancing the cost of achieving the additional quality, its perceived magnitude and the practicalities of making the consumer equipment.

Broadcasters should furthermore consider not just the images but the sound as well. The SHV system is 'three dimensional' in that it can create sound images laterally in two dimensions and vertically. It does this by means of three layers, which use a total of 22.1 sound channels. The result is magnificent, but is it the best overall balance of performance?

The ITU has set up 'Rapporteur Groups' on the three key frontiers that are 'beyond HDTV':

- Ultra High Definition (which includes SHV);
- Sound that is beyond today's surround sound;
- 3D TV.

Broadcasters need to contribute in all these areas over the coming years, in spite of the economic depression, for the sake of our children. As for me personally, I am wondering if the wife would allow all the loudspeakers and wires for a 22-channel audio system, together with a giant screen, at our home in Geneva. Probably not, but could this become just a 'normal' decision for future generations?

David Wood

Deputy Director, EBU Technical

22 January 2009

Editorials Archive

We also get a lot of unwanted spam. So if you would like to contact EBU Technical Review, please address an e-mail to techreview@ebu.ch – but insert an underscore between "tech" and "review", i.e. write it as "tech_review".



Super Hi-Vision

— the star of the show!

Yoshiaki Shishikui, Yoshihiro Fujita and Keiichi Kubota

NHK STRL

On 12 September 2008, at 10 o'clock in the morning, more than 100 members of the press packed into the 50-seat NHK Theatre at IBC Amsterdam to witness the world's first international transmission of Super Hi-Vision programming. In the sweltering room, the potential and feasibility of Super Hi-Vision were demonstrated by the images displayed on the 275-inch screen, which were transmitted live from London City Hall and also as pre-recorded programming from Turin.

An experiment – born of meticulous planning and cooperation by eight organizations over the course of a year – was very successful and it was the most eye-catching demonstration at IBC-2008.

This article describes the collaboration between members of the Broadcast Technology Futures (BTF) group that made these demos possible.

The Super Hi-Vision (SHV) system is being developed by the NHK Science & Technical Research Laboratories (NHK STRL) as a future broadcast system that will give viewers a much greater sensation of reality. The video system has 7680 × 4320 pixels and delivers images so real that viewers almost feel they are present at the scene of the broadcast; they may even find themselves trying to touch what's on the screen. The 22.2 multichannel sound system consists of three vertical layers of loudspeakers. It produces three-dimensional spatial sound that augments the sense of reality and presence.

The first appearance of Super Hi-Vision in Europe was at IBC-2006. That demonstration was carried out by NHK and various Japanese companies but it triggered an international collaboration on broadcast technology. In 2007, four broadcast media laboratories from Europe and Japan (NHK STRL, BBC R&I, the IRT and RAI CRIT) formed a group named the **Broadcast Technology Futures** (BTF) group to work on new technologies for tomorrow's media.

The group – which is assisted by the Technical Department of the EBU – exchanges information to help define the future of media technologies. Their current projects include collaborations on meeting technological challenges related to current media and on media beyond HDTV.

A major collaborative demonstration was arranged for September 2008 at IBC – by NHK, the BBC and RAI, supported by the EBU, Eutelsat, Siemens, Cable & Wireless and SIS – to highlight the international transmissions of Super Hi-Vision programming. This collaborative exhibition proposal was made a year in advance and came true after many preliminary experiments, plans and studies had been conducted.

Overview of the Super Hi-Vision System

History

In late 1990, NHK's research scientists asked themselves, "What's next, after HDTV?" That was the starting point of our research on Super Hi-Vision. Just like in the 1960s, when STRL scientists began thinking about HDTV, our engineers started to dream of a future television system.

Some engineers began work on a 3D television system based on the principle of integral photography. Such a system does not require special glasses; when you move your head, parts of the background hidden by objects in the foreground appear. Our research on integral TV has so far produced a system with QQVGA (Quarter Quarter VGA) quality. To improve the picture quality, we need to create capture and display devices with many more pixels.



Figure 1
A futuristic living room

Other engineers began work on the Super Hi-Vision system for the living room arrangement shown in *Fig. 1*. To make this system a reality, we have to develop capture and display devices that have 33 million pixels.

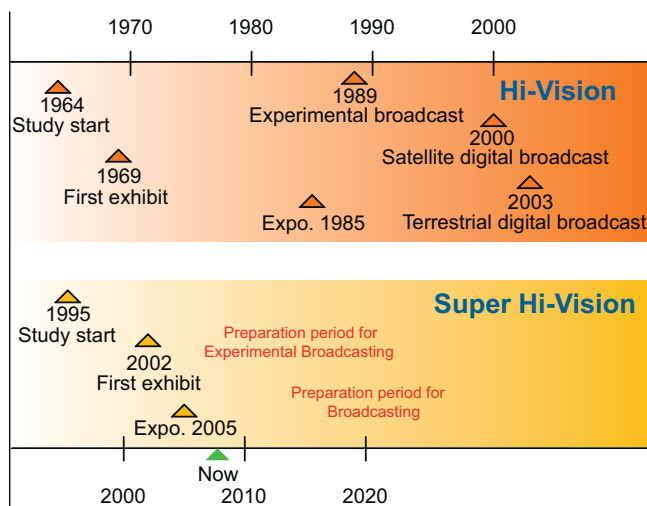

Figure 2
Roadmap

Both teams understood that the 3D television and Super Hi-Vision systems share a common technological ground. NHK began its basic research on post-HDTV in 1995, and formally decided to develop the Super Hi-Vision system with 33 million pixels and its associated equipment in 2000.

The first demonstration of Super Hi-Vision took place at the STRL Open House in 2002. We then took the system to the NAB show in Las Vegas and IBC in Amsterdam in 2006. We also gave a demonstration at Broadcast Asia in Singapore in June 2008.

Fig. 2 shows a roadmap of Super Hi-Vision research and development in comparison with that of Hi-Vision.

Video system of Super Hi-Vision

The video format of the Super Hi-Vision system is shown in *Table 1*. The number of pixels is 7680 horizontally and 4320 vertically, for approximately 33 million pixels per frame. That is four times as many pixels in the vertical and horizontal directions as for HDTV, meaning that Super Hi-Vision overall has 16 times as many pixels as HDTV.

Table 1
Comparison of video formats of HDTV and Super Hi-Vision

	Number of pixels (H x V)	Aspect ratio	Field / Frame frequency	Interlace ratio
Super Hi-vision	7680 x 4320	16:9	60.00 Hz 59.94 Hz	1:1
HDTV	1920 x 1080	16:9	60.00 Hz 59.94 Hz	1:1 2:1

The frame frequency is 60 Hz progressive, so the total information density of the Super Hi-Vision image is 32 times that of HDTV, i.e. 16 times spatially and two times temporally.

International standardization of the Super Hi-Vision format is currently underway. ITU-R has been studying large-screen digital imagery (LSDI) and extremely high-resolution imagery (EHRI), and has produced Recommendations for those image systems. The image format of Super Hi-Vision is in accordance with those standards. In particular, Recommendation ITU-R BT.1769 is based on the R&D results of Super Hi-Vision.

Table 2 shows the relationship between Super Hi-Vision, LSDI and EHRI.

Table 2
Image formats in ITU recommendations

Image format	TV Recommendation	EHRI hierarchy	LSDI Recommendation
1920 x 1080	Rec. ITU-R BT.709 (HDTV)	EHRI-0	Rec. ITU-R BT.1680
3840 x 2160		EHRI-1	Rec. ITU-R BT.1769
5760 x 3240		EHRI-2	
7680 x 4320	[Super Hi-Vision]	EHRI-3	Rec. ITU-R BT.1769

The standardization process with our North American colleagues at SMPTE began in June 2007. They quickly produced SMPTE standard 2036 in 2007, which describes the image formats for an Ultra High-Definition TV system. It harmonizes well with the ITU-R recommendations.

Sound system of SHV

The audio format of the Super Hi-Vision system is 22.2 multichannel sound, as shown in Fig 3 and Table. 3. The 22.2 multichannel sound system has three loudspeaker layers (top layer, middle layer and bottom layer), and it consists of 22 full-bandwidth channels and 2 LFE (low frequency

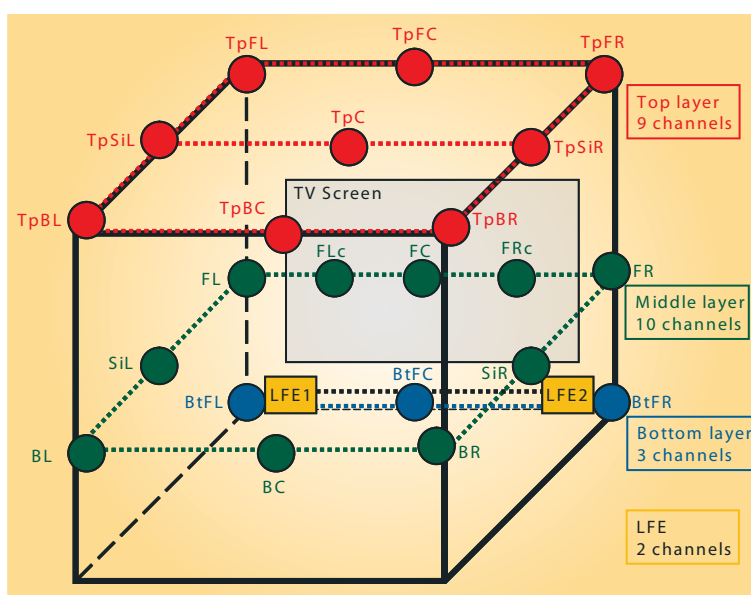

Figure 3
Loudspeaker layout of 22.2 multichannel sound system

effects) channels. It is a three-dimensional sound system, whereas the 5.1 multichannel sound system specified in ITU-R BS.775-2 is a two-dimensional sound system without a vertical dimension.

Table 3
Channel maps and labels of 22.2 multichannel sound

AES Pair No. / Ch No.	Channel No.	Label	Name
1/1	1	FL	Front left
1/2	2	FR	Front right
2/1	3	FC	Front centre
2/2	4	LFE1	LFE-1
3/1	5	BL	Back left
3/2	6	BR	Back right
4/1	7	FLc	Front left centre
4/2	8	FRc	Front right centre
5/1	9	BC	Back centre
5/2	10	LFE2	LFE-2
6/1	11	SiL	Side left
6/2	12	SiR	Side right
7/1	13	TpFL	Top front left
7/2	14	TpFR	Top front right
8/1	15	TpFC	Top front centre
8/2	16	TpC	Top centre
9/1	17	TpBL	Top back left
9/2	18	TpBR	Top back right
10/1	19	TpSiL	Top side left
10/2	20	TpSiR	Top side right
11/1	21	TpBC	Top back centre
11/2	22	BtFC	Bottom front centre
12/1	23	BtFL	Bottom front left
12/2	24	BtFR	Bottom front right

The audio sampling frequency is 48 kHz, and 96 kHz can be optionally applied. The bit depth is 16 bits, 20 bits or 24 bits per audio sample.

International standardization of the 22.2 multichannel sound system is currently underway.

ITU-R is studying the system parameters for digital multichannel sound systems. The standardization process also started at SMPTE in December 2007. In fact, SMPTE has already produced SMPTE standard 2036-2, which describes the audio characteristics and audio channel mapping of 22.2 multichannel sound for production of ultrahigh-definition television programmes. A project at IEC/TC100 is also underway to establish a new standard for the general channel assignment of multichannel sound, including the channel mapping for 22.2 multichannel sound.

Planning and cooperation for IBC 2008

Demonstration systems

The Super Hi-Vision technologies demonstrated at IBC-2008 by the international collaboration group included baseband audio-visual systems, live international transmission over an ultra-broadband IP network and via satellite, and a wavelet-based video compression system. Fig. 4 depicts the configuration of the system that was demonstrated.

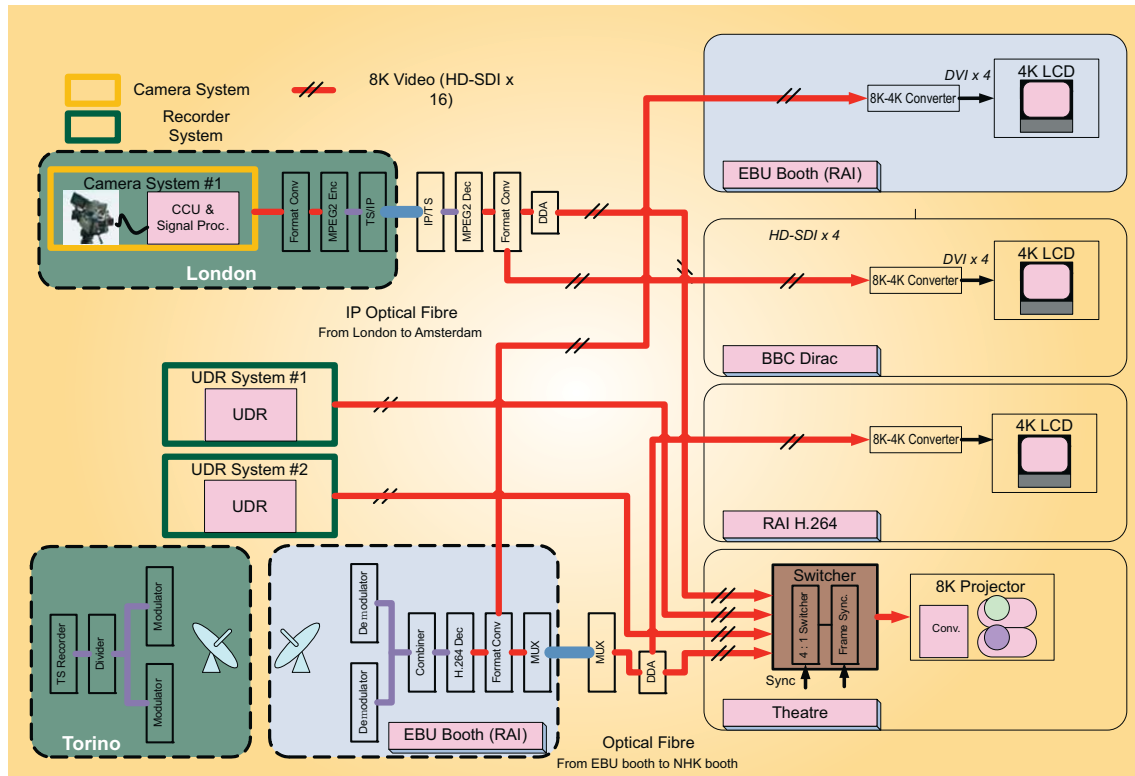

Figure 4
Configuration of the demo system

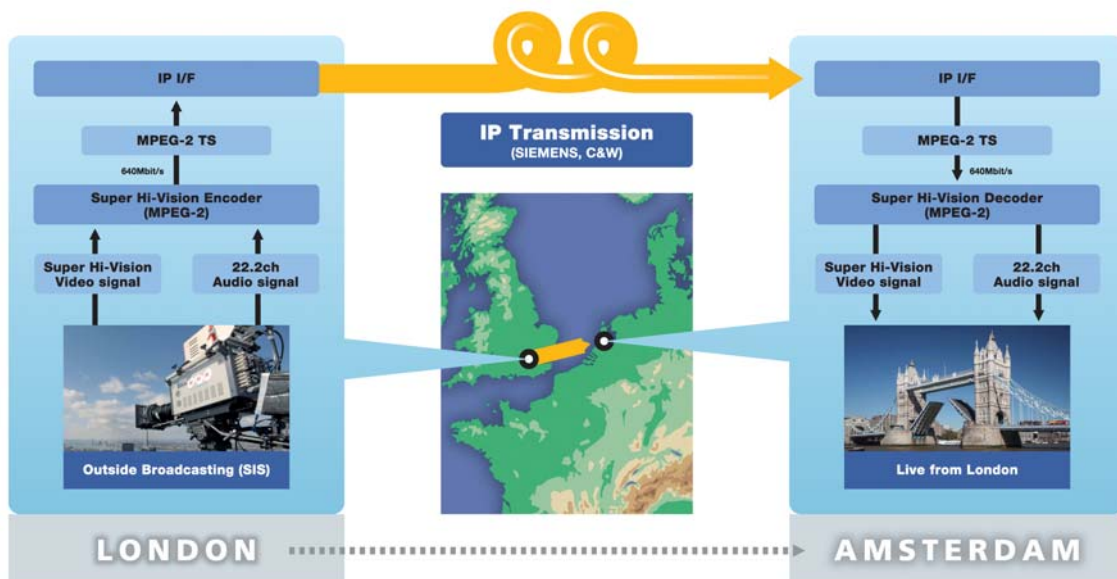

Figure 5
IP transmission of Super Hi-Vision

IP Transmission of Super Hi-Vision (Fig. 5)

The live Super Hi-Vision pictures and sound, captured by the SIS crew in central London, were sent to Amsterdam over an ultra-broadband IP network provided by Siemens and C&W. Ultra-broadband networks are becoming more widely available, so this demonstration showed the possibility of live Super Hi-Vision content being relayed from virtually anywhere in the future.

The 24 Gbit/s SHV signal was compressed to approximately 600 Mbit/s by using MPEG-2. The compressed video and uncompressed 22.2 multichannel audio were multiplexed on an MPEG-2 TS.

Satellite transmission of Super Hi-Vision (Fig. 6)

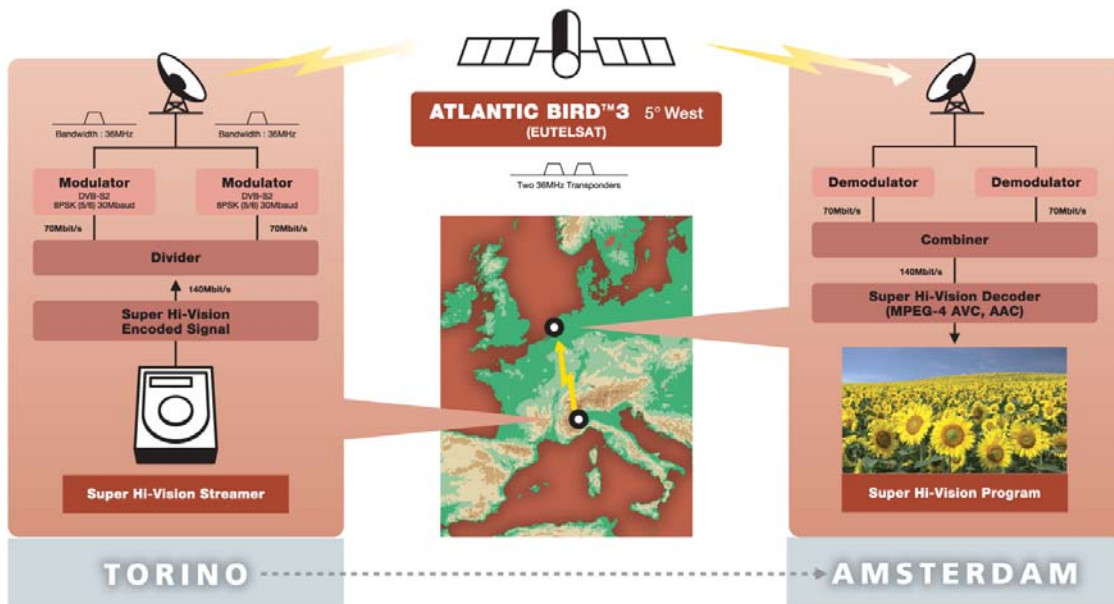

Figure 6
Satellite transmission of Super Hi-Vision

RAI and Eutelsat provided Super Hi-Vision material live via satellite from Turin, using DVB-S2 modulation with a channel efficiency that closely approaches the theoretical limit. The Super Hi-Vision video and the 22.2 multichannel sound were coded using MPEG-4 AVC and AAC, respectively. The 140 Mbit/s coded signal was divided into two transport streams (TS) and carried over two satellite transponders, using 8PSK 5/6 modulation. In the future, a Super Hi-Vision signal may be delivered to the home by Ku or Ka band satellites, using a single high-power 36 - 72 MHz transponder and high-order modulation schemes.

Video Compression: "Dirac" for Super Hi-Vision (Fig. 7)

Dirac is a video compression system devised by the BBC. NHK and the BBC are working together to develop Dirac compression for Super Hi-Vision. Dirac is based on wavelets – a different technology from MPEG. It does not break a picture up into blocks or compress each block in turn. Instead, pictures are delivered by means of a series of approximations of increasing resolution. This means that

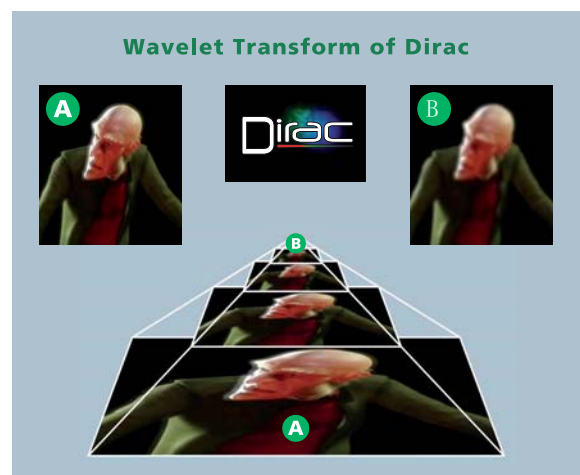

Figure 7
Dirac

Dirac can compress very high resolution images like Super Hi-Vision extremely efficiently, with detail sent only when it is needed.

Collaboration

Transmission

NHK, the BBC, Siemens and C&W cooperated on the IP transmission of the Super Hi-Vision data. The satellite transmission was handled by NHK, RAI and Eutelsat.

Between late 2007 and early 2008, the transmission paths that could be used were investigated. Then, the experiments listed below were conducted prior to the transmission experiment at IBC-2008.

Table 3
Preliminary experiments

Month (in 2008)	Organization	Item
February	RAI, Eutelsat	Measurement of transmission characteristics using the Eutelsat satellite
April	NHK, the BBC, Siemens, C&W	Testing of the IP transmission quality of the SHV signal using a test line originating at BBC Television Centre and turning back at Glasgow, about 500 km to the north.
May	NHK, RAI	Connection of RAI DVB-S2 modems and an NHK codec via a TS divider / combiner, and testing of the SHV transmission over that system.
June	NHK, RAI, Eutelsat	Testing of the SHV signal satellite transmission quality with the transponders of the Eutelsat Telecom 2D satellite and Atlantic Bird No. 3.
August	NHK, the BBC, Siemens, C&W	Testing the stability of the SHV signal transmission using the line between London City Hall and the Amsterdam Rai Centre that would be used at IBC.

During IBC, engineers from the various organizations cooperated in London, Turin and Amsterdam to conduct the transmission experiment (Figs 8, 9).



Figure 8
Transmission site in London



Figure 9
Transmission site in Turin



Figure 10
OB production on the roof of London City Hall



Figure 11
The 275-inch screen in an Amsterdam theatre

Production

The Super Hi-Vision materials were produced in London by a team that included members from NHK, SIS, Siemens and the BBC. The team used a SIS microphone array and other such equipment along with the NHK Super Hi-Vision equipment (*Fig. 10*). A BBC producer and NHK technical staff operated the press showing in the NHK Theatre at the Rai Centre in Amsterdam.

Exhibition

Demonstration content

The international transmissions were presented on a 275-inch screen in a 50-seat Amsterdam theatre (*Fig. 11*). The transmitted content is described below.

IP transmission experiment

The camera and microphones were set up at London City Hall (*Fig. 12*). Tower Bridge and other city scenery viewable from the City Hall were shot by the camera (*Fig. 13*). The video was compressed by MPEG-2 and transmitted to Amsterdam. The images were shown in the theatre, where the inter-



Figures 12
Location of camera and microphones at City Hall in London



Figure 13
View of Tower Bridge from the Super Hi-Vision camera position



Figure 14
Outside the NHK theatre in Amsterdam



Figure 15
Entrance to the NHK theatre in Amsterdam

action between the Master of Ceremonies and the City Hall reporters was enjoyed. It was also continuously shown on a 62-inch 4k display, placed outside the theatre (Fig. 14).

Satellite transmission experiment

The video from a server, set up in Turin, was compressed by H.264 and transmitted via satellite for presentation in the Amsterdam theatre. It was also shown on a display composed of four 56-inch 4k displays set up near the theatre entrance (Fig. 15) and on a 56-inch 4k display at the EBU Village (Fig. 16).

Uncompressed content

The content compressed with MPEG-2 or H.264 was presented in the theatre, but to experience the true quality of Super Hi-Vision, uncompressed content was also presented. Furthermore, a video called “The Making of Super Hi-Vision” was presented at the press showing, along with still images comparing the pixel densities from those of standard TV up to Super Hi-Vision.



Figure 16
Super Hi-Vision demo at the EBU Village



Figure 17
Super Hi-Vision demo at the Eutelsat booth

An uncompressed Super Hi-Vision programme was also shown at the Eutelsat booth on a 56-inch 4k display (Fig. 17).

Results

The demonstration went smoothly throughout the duration of the exhibition, with no major complaints or problems. Also, the annoyingly frequent rain in London during the preparation period gave way to marvellously clear skies during the five days of the exhibition, and excellent views of London from City Hall were shown. We were convinced that most visitors to the show in Amsterdam enjoyed watching stunning live images and sound from London.

One visitor who saw the live video from London on the 62-inch display even made a phone call to an acquaintance seen walking on Tower Bridge to tell them to face the camera at City Hall !



Figure 18
The press showing at IBC



Figure 19
Dr Nagai, managing director of NHK (left) and Lord Digby Jones (right)

The Super Hi-Vision exhibit was a big attention-grabber at this year's IBC. At the press showing before the opening to the general public, there were more than twice as many press members as available seats in the theatre (Fig. 18). Several TV crews attended and videotaped the show.

5180 persons, including VIPs from various countries, visited the NHK Theatre and experienced Super Hi-Vision. One such visitor was Lord Digby Jones, British Minister of State for Trade and Investment (Fig. 19).

Visitors offered the following praise.

“ I should congratulate you on this system’s very good quality and very impressive transmission capabilities, combining satellite delivery with fibre delivery. With that level of resolution and audio quality, I can see that it’s not just for entertainment but for educational purposes, for medical purposes, for a whole range of possibilities. ”



Figure 20
IBC award ceremony

“ It was a wonderful demonstration. The content, too, was impressive. Seeing is believing. Please do a demonstration in our country, too. ”

“ The Super Hi-Vision show was thoroughly enjoyable. This is NHK setting the blueprint for the future, as you did with HDTV many years ago. ”

The success of this, the world's first international Super Hi-Vision transmission experiment, earned the Special Award from IBC (Fig. 20).

Future development (NHK's short-range research target)

At IBC-2006, NHK demonstrated a Super Hi-Vision camera and other equipment in our booth and, in the Super Hi-Vision theatre, we presented a Super Hi-Vision programme and live images that were captured at the convention site. The Super Hi-Vision signals were transmitted over optical fibre links. All equipment and transmission lines were set up within the Rai Centre.

With the success of this experiment at IBC-2008, the transmission of Super Hi-Vision signals has made a great stride forward from the 2006 demonstration.

What remained unchanged, however, were the camera and the display. We used the dual-green technology for both. For those who are not familiar with the dual-green system, it uses four imaging devices with 8 million pixels, two of which are used for the green channel and the remaining two are used for the red and blue channels. This means the cameras and the displays do not have the full resolution of the Super Hi-Vision system. Imaging devices with 33 million pixels were not available when the cameras and displays were developed.

Another important point is that the display device used for both demonstrations was a projector, not a direct-view display.

This clearly points the way to our next research targets, that is, the development of a full-resolution camera and a direct-view display. We will develop a prototype full-resolution camera with three 33-million-pixel image sensors by early 2011. We expect that display manufacturers will develop a flat-screen display with the full pixel count by 2011, as well. Furthermore, we will develop a full-resolution projector by the end of 2009.

By developing such cameras and direct-view displays, we can provide people with the first experience ever to see Super Hi-Vision images with full resolution in a home viewing environment. We believe this advance will be indispensable for determining the signal parameters of future broadcasting.

Besides developing the cameras and displays, we are developing compression techniques. A video bitrate of 130 Mbit/s was used for this year's IBC transmission experiment via satellite. We will be able to compress the Super Hi-vision signal to 90 Mbit/s by early 2010. Hopefully, we can conduct a transmission experiment over a single transponder of a broadcasting satellite around 2011.

Conclusions

This historic Super Hi-Vision demonstration at IBC-2008 was a resounding success. The progress made by it can be summarized as follows:

1) Participants

Two years ago, NHK and Japanese companies formed a team to bring Super Hi-Vision to Amsterdam. This year, NHK, the BBC, RAI and the EBU teamed up to accomplish the first international transmission of Super Hi-Vision signals with the cooperation of network operators and equipment manufacturers. The effort to develop a future television system has spread from Japan to Europe.

2) Transmission technologies

In 2006, signal transmissions were limited to within the convention site. This year's IBC demonstration involved the world's first international transmission of Super Hi-Vision signals over an ultra-broadband IP network and via satellite. This advance is due to improvements in signal compression, IP and satellite transmission technologies.

It is our responsibility to convince broadcasters, viewers, equipment manufacturers and network operators across the globe that Super Hi-Vision is not just a dream, but a real future television



Yoshiaki Shishikui received B.Sc., M.Sc. and Ph.D. degrees in electrical engineering from the University of Tokyo, Japan, in 1981, 1983 and 1997, respectively. He joined NHK (Japan Broadcasting Corporation), Tokyo in 1983. Since 1986 he has been with NHK STRL (Science and Technical Research Laboratories), where he has been engaged in research on digital signal processing, picture coding, HDTV broadcasting systems, IPTV systems and advanced data broadcasting systems.

Dr Shishikui is now a senior research engineer and the leader of the advanced services research group at NHK STRL. From 2001 to 2003, he was with NHK Engineering Services Inc., where he helped to develop video archives and video-on-demand systems. He has been a part-time instructor at several universities in Japan and has been actively involved in standardization activities at SMPTE and ISO-IEC (MPEG).

Dr Shishikui served as Associate Editor for IEICE Transactions D (Japanese) from 1997 to 2001. He received the Best Paper Award from ITE Japan. He is a member of both ITE Japan and IEICE Japan.

Yoshihiro Fujita received B.Sc. and Ph.D. degrees in electronic engineering from the University of Tokyo, Japan, in 1976 and 1998, respectively. He joined NHK (Japan Broadcasting Corporation), Tokyo, in 1976. He has more than 25 years' research experience at NHK STRL (Science and Technical Research Laboratories). He started research on advanced imaging systems for HDTV and post HDTV. He holds several awards from ITE Japan for developing Dual-Green camera systems. At present, he is an executive research engineer and is engaged in standardization activities and coordination of international collaborative research.

Dr Fujita currently serves as chairperson of the Digital Broadcasting, R&D DTB group at ARIB (Association of Radio Industries and Businesses) Japan and is a member of the IEEE, IEICE and ITE Japan.



Keiichi Kubota joined NHK (Japan Broadcasting Corporation) in 1976. From 1979 to 1980, he was a visiting engineer at the CBS Technology Centre in the USA. Since August 1980, he had been with the Science and Technical Research Laboratories of NHK, working in the areas of satellite transmission systems for HDTV, signal processing for HDTV and subjective assessment of HDTV picture quality.

From 1989 to 1993, Dr Kubota was the Senior Scientist at NHK's New York Office. During this period he participated in various HDTV standardization activities in SMPTE, ATSC and the FCC Advisory Committee on ATV Service. In 1993, he was transferred to NHK Laboratories as the Senior Research Scientist and, later, the Deputy Director of Advanced Television Systems Research Division, where he was in charge of research activities in digital coding of HDTV. In 1996 he was transferred to the Planning Division of the Engineering Administration Department as the Senior Associate Director, where he was responsible for starting NHK's digital satellite broadcasting service.



From 2001 to 2005, Keiichi Kubota was Director of the Planning and Coordination Division, and then the Deputy Director of the Laboratories. From 2005 to 2007, he was in charge of the nationwide rollout of NHK's terrestrial digital broadcasting services, serving as Engineering Controller for the Engineering Administration Department. Currently, he is the Director-General of the NHK Science and Technical Research Laboratories.

Dr Kubota received his B.Sc. and Ph.D. degrees from the University of Tokyo in 1976 and 1987 respectively, and is a fellow of SMPTE and IEEE.

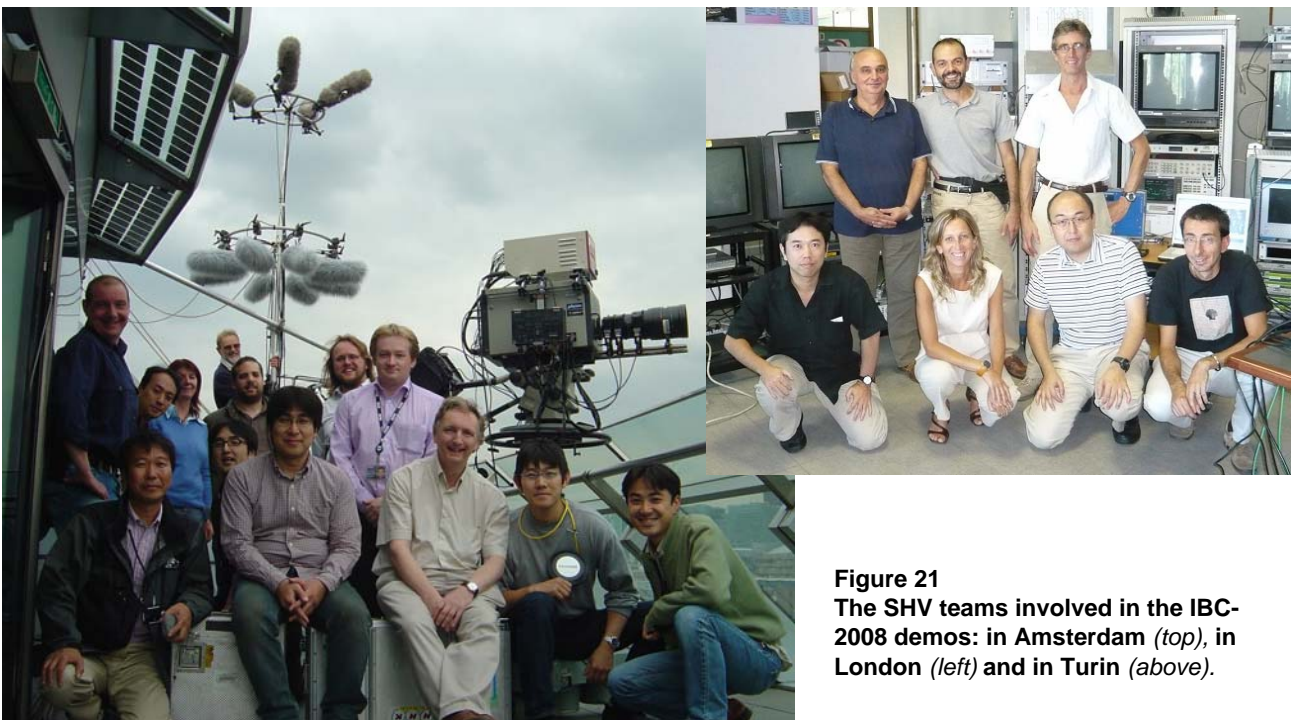

Figure 21
The SHV teams involved in the IBC-2008 demos: in Amsterdam (*top*), in London (*left*) and in Turin (*above*).

system, and we think we can meet this responsibility by showing everyone real Super Hi-Vision images.

The success of this demonstration rests on the contributions of many organizations, including the IBC, the Rai Centre in Amsterdam and the City of London, and the devoted efforts of many support staff members as well as on the work of the eight partner organizations. The authors would like to conclude by thanking everyone who was involved in this project.

Super Hi-Vision

— the London-Amsterdam live contribution link

John Zubrzycki, Thomas Davies
BBC R&D

Peter-Calvert Smith
Siemens IT Solutions and Services

Paul Styles
Cable&Wireless

Bill Whiston
SIS LIVE

Yukihiko Nishida, Masaru Kanazawa
NHK STRL

The first international Super Hi-Vision (SHV) contribution link took place in September 2008. Live pictures from London were shown in a specially-built theatre, constructed in Amsterdam for the International Broadcasting Convention (IBC-2008). The link used standard telecommunications circuits to demonstrate that, in principle, it is feasible to backhaul contribution-quality SHV signals from anywhere in the world that has access to broadband telecommunications.

This article gives an overview of the SHV system and then describes the transmission equipment used, the operations at the outside broadcast site in London, the link to Amsterdam and the reception in the SHV Theatre. Finally, the application of a new coder – called Dirac – to SHV, and other further work, are outlined.

Super Hi-Vision production equipment

Super Hi-Vision is a type of Ultra-HDTV (UHDTV) system with four times as many lines and pixels per line as HDTV. *Table 1* shows the specifications of Super Hi-Vision compared with those of HDTV. Super Hi-Vision's format is recommended in ITU-R [1] for extended LSDI (Large Screen Digital Imagery) systems and in SMPTE [2][3] for UHDTV.

Because high resolution motion image sensors of 33 M pixels were not available at the time, a camera system with the pixel offset method, combining four (R, G1, G2 and B) of 8 M CMOS sensors, was developed [4]. *Table 2* shows the specifications of the camera [5] and *Fig. 1* shows the appearance. The camera is equipped with a 5x zoom lens and the camera head can be set

apart from the CCU (camera control unit) up to 1,000 metres, using optical camera cable. The total bitrate of the camera output is 24 Gbit/s.

Table 1
Specifications of the Super Hi-Vision system

	HDTV	Super Hi-Vision
Pixel Number	1920×1080	7680×4320
Aspect ratio	16:9	16:9
Frame frequency	60 Hz Interlace	60 Hz Progressive
Designed viewing angle (pixels invisible)	30 deg. horizontally	More than 100 deg. horizontally
Coding format	Linear 8 or 10 bit/component	Linear 10 or 12 bit/component
Colorimetry	ITU-R BT.709	ITU-R BT.709
Audio	5.1 ch.	22.2 ch.
Comparison with movies	Equivalent to 35-mm movie film	More than twice that of 70-mm movie film

Table 2
Specifications of the Super Hi-Vision camera

Item	Specifications of SHV camera
Video format	Super Hi-Vision Nominal resolution 7680×4320 with pixel offset method
Image sensor	8M pixel CMOS(1.25 inch diagonal)
Colour imaging method	Diagonal pixel offset method for Green R, G1, G2, B
Lens	5 × zoom, 12 ~ 60 mm
Sensitivity	2000 lux, F5.6
Signal processing	Video signal enhancement Fixed-pattern-noise cancellation Chromatic aberration correction
Weight	40 kg (camera head with lens)
Distance between camera head and CCU (camera control unit)	1,000 m (max.)
Output	16 × HD-SDI (24 Gbit/s)

Other devices such as hard-disk recorders and display systems have also been developed [6]. With a 3.5 TB capacity, a Super Hi-Vision disk recorder can record and play for almost 20 minutes.

For IBC-2008, a camera head was placed on the top of London City Hall and the CCU with monitoring devices was installed in the machine room.

Super Hi-Vision transmission system

The data rate of uncompressed Super Hi-Vision signal reaches 24 Gbit/s. Compression coding is needed to transmit such an enormous amount of information. A Super Hi-Vision transmission system has been developed for efficient and high-quality transmission of SHV signals [7].

The IP transmission system consists of a video format converter, a video codec and an IP network adapter as depicted in *Fig. 2*. Major specifications of the system are listed in *Table 3*. The video format converter converts the 7680 x 4320 (G1, G2, B, R) format from / into the sixteen 1920 x 1080/30/PsF (Y/Cb/Cr, 4:2:2) images, where the SHV image is divided spatio-temporally. The video codec consists of four sub-codecs for 3840 x 2160 images.



Figure 1
Super Hi-Vision camera

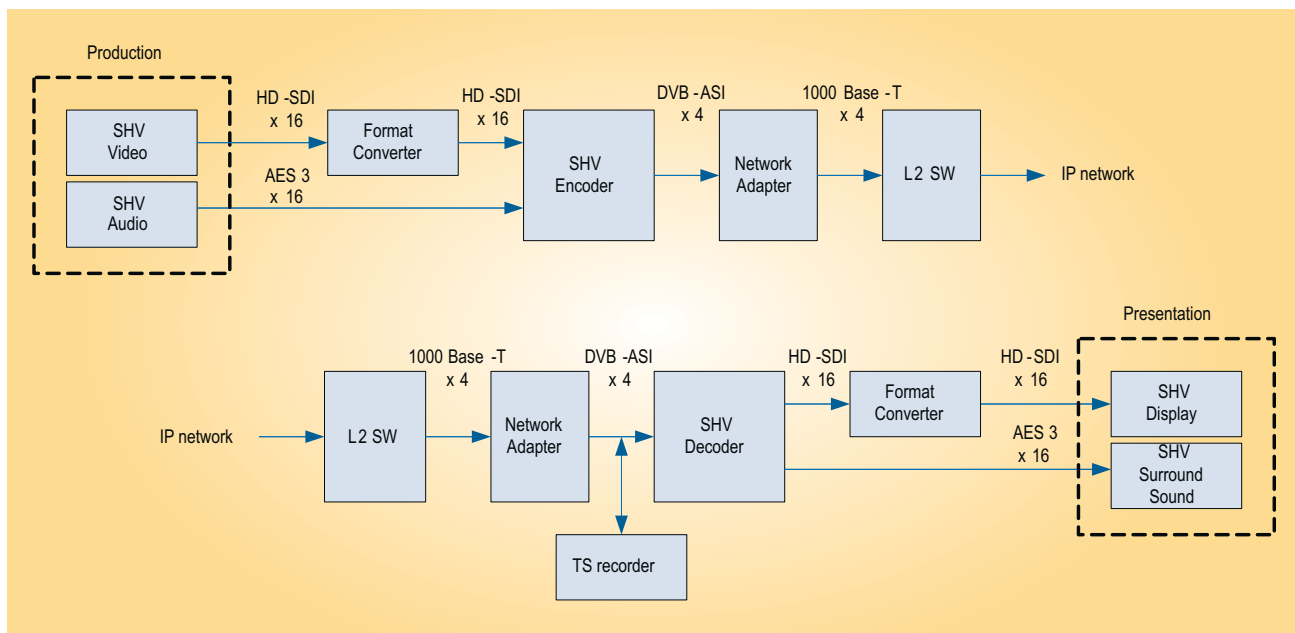

Figure 2
SHV IP transmission system

A sub-codec contains four single-unit MPEG-2 HDTV codecs and a multi-channel frame synchronizer. To compress large images that exceed the resolution of HDTV, when using MPEG-2 video coding, it is necessary to divide the SHV image into multiple HDTV units. The HDTV coding conforms to MPEG-2 Main Profile or 4:2:2 Profile @ High Level.

The 32-channel digital audio signals (AES3-id x 16, approximately 37 Mbit/s) can be multiplexed with video in the MPEG-2 TS as per SMPTE 302M. The coded video and audio signals are multiplexed into four MPEG-2 transport stream (TS) signals, interfaced via DVB-ASI. The IP network adapter is a protocol gateway to convert the TS packets to/from RTP packets. Three types of Forward Error Correction modes are available.

Public IP networks may have some jitter and different time delays depending on transmission paths. To synchronize the four TSs generated by the sub-encoders, the system manages the timing of

Table 3
Specification of SHV IP transmission system

Format converter	Signal format	G1/G2/B/R to Y/Cb/CR (4:2:2)
	Picture division	7680 x 4320/60/P(pixel-offset) to HDTV (1920 x 1080/29.97PsF) x 16
Video coding	Coding scheme	MPEG-2 4:2:2/Main Profile
	Bitrate	180 Mbit/s – 600 Mbit/s
Audio multiplex	Multiplexing scheme	AES3-id data mapping to MPEG-2 PES(SMPTE 302M)
	Bitrate	37Mbit/s (PCM 24bit/48kHz x 32ch.)
A/V multiplexing	Multiplexing scheme	MPEG-2 Systems TS
	I/F	DVB-ASI x 4
	Bitrate	Max. 640 Mbit/s (160 Mbit/s x 4)
IP network adapter	Protocol	RTP/UDP/IP (RFC1889)
	Forward error correction	RS(12, 8)/Pro-MPEG 5x20/Pro-MPEG 10x10/ OFF
Transport stream recorder	I/F	MPEG-2 TS (DVB-ASI) x 4-ch
	Recorded signal	Time-Stamped TS for synchronous playback

each video frame using a timecode and temporal reference in the GoP header in the MPEG-2 video stream. The sub-encoders communicate with each other via Ethernet. A master sub-encoder controls the start timing of all the sub-encoders.

At the decoder (*Fig. 3*), a master sub-decoder adjusts the display timing of all the sub-decoders and accounts for the transmission delays by referring to the timecode and the temporal reference. The decoder can cope with the relative delays (up to 15 video frames) in the four TSs. All the HDTV decoders in the sub-decoders work synchronously using black burst as a reference signal.

A TS recording device has also been developed, which supports the storage of long-duration programme content. Time-stamped TS packets are recorded to enable synchronous playback of the four transport streams. The storage capacity of 1.2 TBytes enables storage of 4.5 hours of programmes at a bitrate of 600 Mbit/s.

On 31 December 2006, NHK – in collaboration with Nippon Telegraph and Telephone Corporation (NTT) and NTT Communications Corporation – carried out a live, long-haul SHV test transmission via gigabit IP networks over a distance of 500 km from Tokyo to Osaka in Japan [8]. The NHK TV programme called “Kohaku Utgassen” is a live musical variety show that is broadcast for about five hours every New Year’s Eve. The transmitted programme was screened at a special theatre. The total TS bitrate was 640 Mbit/s and the total system delay was approximately 700 msec, which was dominated by the codec delay. FEC was not used but there was no packet-loss for the duration of the event. This experiment verified that long-haul SHV video transmissions were feasible. The new London-Amsterdam experiment, in which the



Figure 3
Receiving equipment at the SHV Theatre

640 Mbit/s TS plus Pro-MPEG FEC 5x20 was carried, proved that it is practical to send SHV signals internationally across several networks operated by different companies.

London-Amsterdam link

The aim of this link was to demonstrate the feasibility of transmitting live Super Hi-Vision pictures and sound internationally over public telecoms networks. The SHV signal would be routed through three networks (two public networks and a broadcaster's network), plus temporary private networks set up at each end of the link.

The place chosen to be the location of the outside broadcast was London City Hall on the South Bank of the River Thames, which provided iconic views of London. This location was made available with the kind permission of the Greater London Authority.

The camera and microphones were set up on the balcony of City Hall, while the sound control, video/audio coding equipment and network multiplexers were installed in a basement room. In another basement room nearby, there is a fibre-optic node on the London Fibre Network (LFN), operated by Siemens for use by broadcasters. The LFN carried the coded SHV signal as an IP packet stream to an access node of Cable&Wireless network at BBC Broadcasting House in the centre of London. The signal was then multiplexed with other telecoms traffic and carried via an international fibre-optic undersea cable link to Amsterdam, where it was handed over to KPN, the Dutch PTT, who carried the signal into the RAI Centre exhibition halls. The signal was then carried, using fibre-optic cables installed by Siemens, across the exhibition halls to the SHV Theatre located in Park Foyer, where the SHV signal was decoded for display in the theatre (*Fig. 4*).

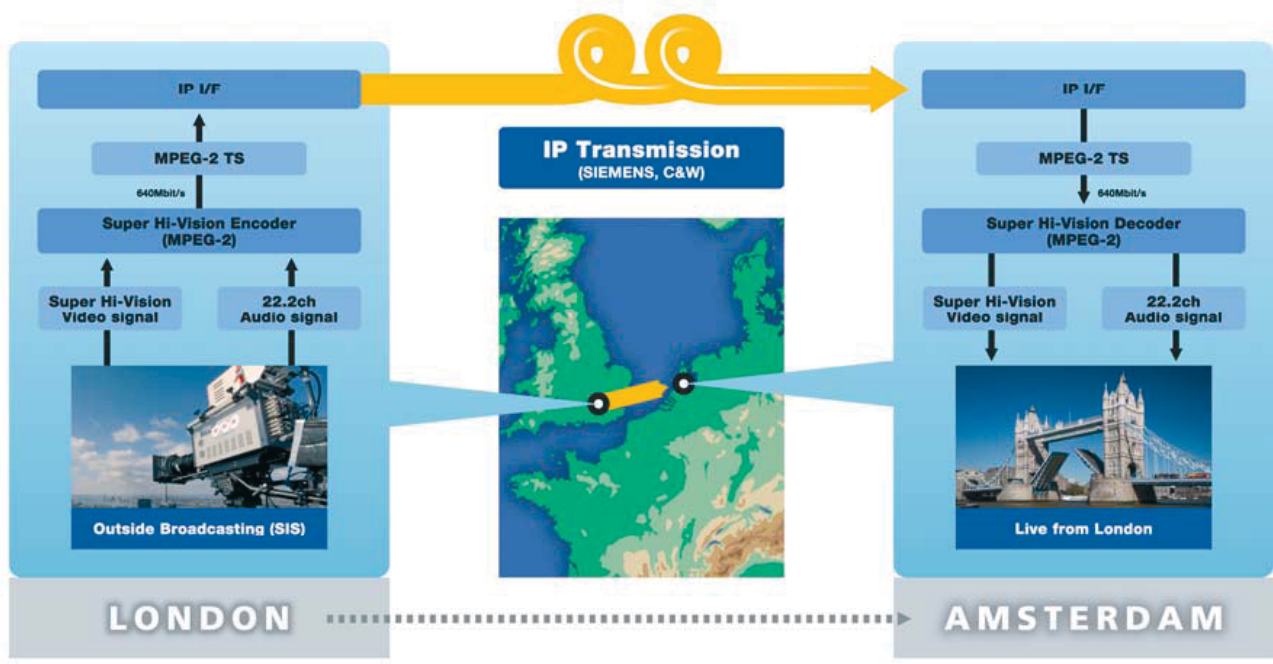

Figure 4
London-Amsterdam link

London City Hall location

The camera was positioned on the top of the City Hall, the home of the Mayor of London and the Greater London Authority (GLA). This location was suggested by Peter Weitzel of Siemens IT Solutions and Services, Media Systems, for practical and aesthetic reasons; iconic views of Tower Bridge and the Tower of London, and the available fibre connections. The fibre is provided as part of the Siemens' London Fibre Network (LFN). All that had to be provided specially was local-fibre

camera and audio connections from the roof to the LFN termination point and to the temporary control room in the basement. A recce of City Hall and other possible sites by NHK and the BBC led to this site being selected early in 2008. Our thanks go to the GLA for their permission to use this building and to the GLA staff for all their help.

The operation used three areas: roof balcony (camera position), control room and apparatus room.

The apparatus room had the camera cable, audio and fibre patching, and the wavelength division multiplexers (WDMs) connected to the LFN.



Video monitoring



4x4 video encoders and IP adapters



Camera control unit

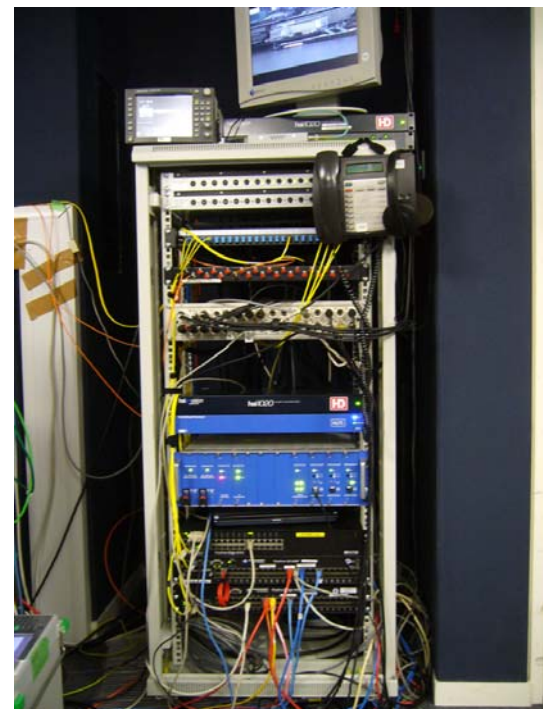

IP switch and network interface

Fig. 5
Equipment in the City Hall basement control room

The control room was “installed” in an interview studio, part of the City Hall media facility in the basement. It contained audio monitoring and control, camera control and monitoring, signal format conversion, coding, multiplexing and Ethernet routing. There was easy cable routing to the apparatus room, and City Hall was able to augment the ventilation to keep the equipment sufficiently cool (Fig. 5).

On the balcony, the camera – heavy by current standards – was mounted on a conventional pedestal and head (Fig. 6). The microphone array (see next section), radio talkback, HD display, video and audio codecs and an IP router were accommodated here.



Fig 6
The SHV camera on the balcony of London City Hall

The SHV camera’s viewfinder is an HD LCD mounted on the pan bar. It is difficult for camera operators to view focus on HD cameras these days. With SHV it is impossible, so this function is remotely controlled from the control room using a 4k resolution monitor.

Production audio capture

Sound acquisition for this experiment can be divided into three topics:

- 1) The Setup in the Control Room
- 2) The Link from the Array to the Control Room
- 3) The Array.

In conjunction with NHK, the system we decided to adopt for this exercise was a 15.2 system rather than a full-blown 22.2 system. This meant that there would be a middle layer containing eight of the ten specified 22.2 microphone complement, the top layer would be reduced to four microphones from nine, and the lower layer would have the full complement of five microphones, of which two were LFE channels. The total of 18 audio channels, including the 15.2 channels and one commentary channel, were sent individually as separate outputs from the mixing desk, embedded with the

video as AES pairs and sent to Amsterdam to be reproduced for the 22.2 system in the viewing theatre there.

The Setup in the Control Room

A Yamaha LS9-32 digital mixing desk was used for this project. It was fitted with two mini-YGDAI MY16-AE AES interface cards, giving 16 channels of digital audio each, in and out of the desk. A LightViper digital stagebox system fed the microphone outputs from the roof into the LS9-32 via the YGDAI card inputs, the desk outputs being sent to the video embedders via the YGDAI card outputs. As the card outputs are on D-sub 25-pin sockets, a pair of AES-3 flails were used to provide the outputs and several Balun adaptors were used to convert from balanced to unbalanced AES to interface with the video embedders.

Since there wasn't sufficient room in the Control Room for a full 15.2 monitoring system, the LS9-32's OMNI outputs were used to feed eight Fostex 6301 loudspeakers mounted on microphone stands. This represented the complete middle ring of eight microphones. By using programmed presets in the desk, the upper four or lower three microphones could be switched to the relevant speakers for monitoring without affecting the outputs to the embedders. There were six presets in all, three representing full-level monitoring outputs and three introducing a -15 dB reduction in output for each array level. The two LFE channels were routed via OMNI



Figure 7
Bill Whiston at the sound monitoring position

outputs to a BBC LS 3/7 loudspeaker which, because of the lack of space, was used as a seat behind the desk. The LFE monitoring was, therefore, mainly by feel rather than by ear (*Fig. 7*).

A further two Fostex 6301 loudspeaker were used, one to monitor the in-vision radio microphone and the other as a pre-hear, both fed from further OMNI outputs.

A Prospect K6R talkback box was used to feed a radio talkback system installed on the roof, for engineering purposes mainly. A second circuit was used to feed an IEM system to the in-vision talent. Two 4-wire circuits to Amsterdam were also plugged to the K6R, one to the Vision crew and one to the Sound crew.

The Link from the Array to the Control Room

As previously mentioned, a LightViper digital stagebox system was used to bring the microphone circuits from the array to the Control Room. This was by fibre link from the roof of City Hall, nine storeys up from the basement via an Apparatus Room, also in the basement. Two short star quad multis were used to bring the circuits from the array to the fibre box.

Feeds to a radio talkback system, IEM reporter system and a backup cable talkback system to the basement arrived via copper XLR tielines from the basement, also via the Apparatus Room. A second digital fibre system was arranged by NHK as a backup for the LightViper, based on RME A-D components, but was never fully implemented.

The Array

The array consisted of two aluminium 25 mm tubular rings and a T-bar. The top ring was 60 cm in diameter, the middle ring 90 cm in diameter. The 'T' was 90 cm long with a 45 cm arm. The mounting pole was a 40 mm tube, 240 cm long and a 3 mm wall thickness. The three levels were clamped a metre apart. A lighting stand spigot was fitted at the lower end of the tube to allow us to position and then raise and lower the array. The whole array was secured to the building with a scaffolding pole (*Figs 8 and 9*).



Figure 8
Microphone array and camera



Figure 9
Close-up of microphone array

Most of the microphones were provided by NHK and were a variation on hypercardioid microphones, specially developed by NHK. They came in two styles, one type longer than the other and with a narrower pickup. They both have three capsules which are matrixed together to produce a hypercardioid microphone with a negligible back lobe. The long version has normal condenser capsules; the shorter version has been developed for use with hand-held cameras and has electret capsules.

Four of the shorter microphones (with wider pickup) were used for the top layer. The narrower pickup version was used on the second layer. The lower layer consisted of three Schoeps CMT5 microphones and the LFE coverage was provided by two Schoeps BLM 03 boundary layer microphones, laid on the curved glass structure three metres below the main array and about five metres apart.

All the microphones were mounted in Rycote windgags with Windjammers apart from the LFE microphones which had special Windjammers made for them.

The City Hall–RAI Centre IP link

Siemens built the IP network that used the Cable&Wireless circuits between London and Amsterdam. The Siemens LFN linked City Hall and Siemens commissioned IBC's cable contractors to run fibre over the RAI Centre roofs to the SHV Theatre. *Fig. 10* summarizes the design.

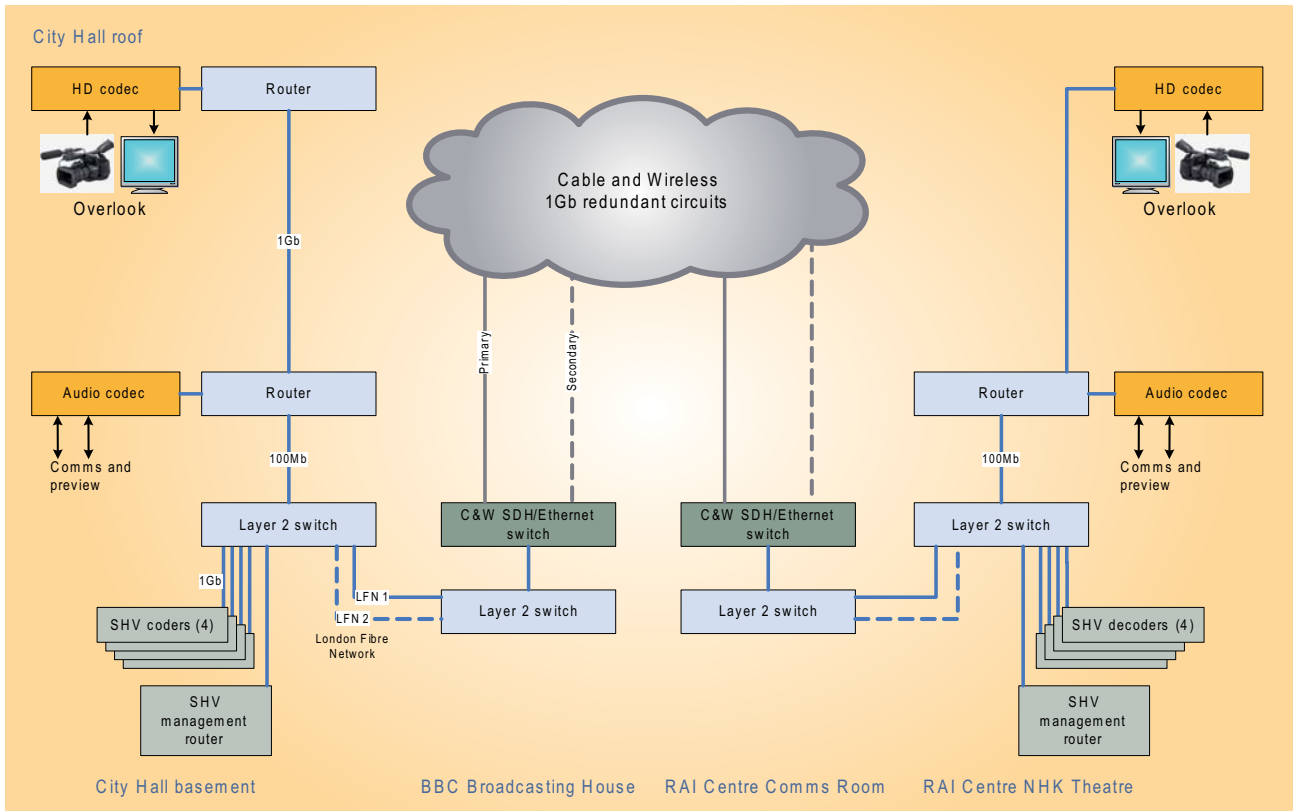

Figure 10
Summary of network design

Main talkback, cue and preview audio between London and Amsterdam was carried over IP by APT Oslo codecs equipped with new 4-wire modules. Additional and reserve communications using conventional phones, ISDN and mobiles were also available in case of major failure of the IP system.

Overlook cameras in the SHV Theatre and at City Hall enabled the presenters and production team to follow each other at work. These cameras were just(!) HD and were coded over the IP link using HaiVision Mako HD MPEG4 codecs.

The connection to Cable&Wireless was made at BBC's London Broadcasting House. Cable&Wireless delivered the link to the RAI Centre via the local telco.

So far as practical, the connection between City Hall and the SHV Theatre was over dual paths, with terminal routers using Metro Ring Protocol (MRP) to provide automatic failover switching. The dual paths of each segment of the route arrived at a single switching site. A permanent dual path connection would normally avoid these single sites, but the risk of single-site failure during this event was very low.

Routers were constantly monitored using methods such as continuous ping. Any failure in an IP connection could be quickly located. In practice, the only 'failures' were those induced for tests or during the pre-show build phase – generally, mistakes in cable patching

Network design and testing

It was vital for all involved that 'the show must go on'. However, installation costs had to be kept sensible – after all, this was not the Olympics. So the design employed basic techniques that Siemens use in enterprise WAN architecture but with a large helping of 'hand-holding' by experts. This is, after all, just normal practice for a live outside broadcast. The design provided redundant paths to protect against cable damage which can take days to repair. However, routers were not redundant as staff were on hand to deal with faults within minutes. A permanent system would normally require additional redundancy.

Space on the GbE link was needed for SHV picture and sound, SHV IP management, cue audio, vision, talkback and network management. The SHV traffic occupied about 850 Mbit/s, which includes 640 Mbit/s TS, Pro-MPEG FEC 5x20 and IP packet headers.

A key test was planned for April 2008. NHK flew SHV equipment and a team to the UK to send SHV IP traffic round a model test network. With Cable&Wireless, Siemens set up a model network using available capacity on the BBC Raman network. A GbE link was constructed that took IP from London to Glasgow and back. Initial testing by Siemens sent uncompressed SD video and audio round this loop, looking for packet loss, latency changes, video and audio quality and lip-sync. No errors were found.

On the Friday that the SHV equipment arrived, a cable forming part of the Raman network was damaged by an excavator and our model network failed. We had no dual paths for this test. Cable&Wireless promptly fixed the fault, and by the start of the SHV tests on the Monday, the connection was fully restored. It was a useful reminder of the importance of providing dual paths.

Another test confirmed the available bandwidth by adding packets from an IP traffic generator, raising the rate until the SHV traffic was interrupted. The design was then refined to guarantee SHV traffic even if other codecs were misconfigured or faulty. Essentially, this was achieved by all other traffic being constrained to a total of 100 Mbit/s. A strategy to deal with any suspected interference with SHV traffic was agreed, with NHK, and tested during the IBC build phase. It allowed the reduction of this total and also the disconnection of all non-essential traffic.

The IBC route was made up from permanent fibre connections (LFN) and GbE circuits booked by Cable&Wireless UK and Cable&Wireless International. At the RAI Centre, temporary cables were provided between the local telco's POP and the SHV Theatre.

Cable&Wireless provided the connection from the end of July and Siemens made initial tests of video and audio performance using HaiVision and APT codecs in August when access to the RAI Centre became available.

Cable&Wireless provided a detailed survey of the paths to show the redundant paths and switching. The survey revealed only two places which had single physical routes that could not economically be separated. One segment was the local connection to the RAI Centre, probably the largest risk, and the other was a short section of duct in the RAI Centre.

Joint tests by Siemens and NHK proved the effectiveness and the effect of the redundant path-switching on the SHV traffic. While the Ethernet traffic was monitored, connections were unplugged to show that the connection was self healing and to see how long it took to make the switch. At Siemens, we had done preliminary tests to establish the shortest switchover time without introducing spurious switchovers. Any interruption of the picture or sound could destroy the viewer's perception of the quality which SHV sets out to deliver.

Video and Audio performance over IP

The issue here is not the basic quality of the picture and sound, nor the effect of compression. Rather it is the effects that IP performance can have on pictures and sound; glitches, freezes, blocking, etc. Siemens has obtained considerable expertise in qualifying audio and video over IP to meet the normal expectations of broadcasters for glitch-free operation and consistent quality. The company is replacing music and vision circuits with IP connections for use by its main customer, the BBC. Most of these circuits use the Raman network and its branches that Siemens and its partner, Cable&Wireless, manage directly. But Siemens is also using international MPLS connections from other providers and has learned much about testing the network and the broadcast performance, and about network and codec configuration.

This enabled Siemens and Cable&Wireless to provide links that were free from jitter and packet loss, and which provided the full bandwidth from the start.

The network design for the redundant paths and routers also benefited from experiences in other projects, especially our operation for the Beijing Olympics.

The International link

Cable&Wireless delivered the Gigabit Ethernet (GbE) service between BBC Broadcasting House in London and the RAI exhibition centre in Amsterdam, across its high capacity optical core network. At either end the interfaces were optical GbE and, in between, the signal was carried as full bitrate GbE, mapped within an SDH framing structure. In this case the bearers were STM-64 (also referred to as 10Gbit/s).

The GbE was mapped into seven STM-1 (155 Mbit/s VC-4) SDH containers. This meant that the GbE shared the 10 Gbit/s and fibre with other BBC services; for example, real time audio and video and other data services. There was no “contention” of the GbE bandwidth. This was felt key to ensuring consistent performance throughout the IBC demonstration.

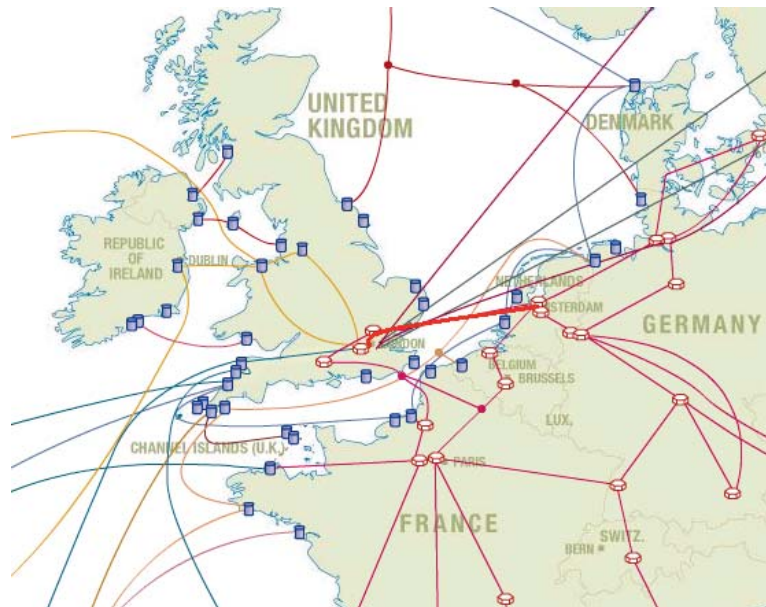

Figure 11
An overview of the route to the RAI exhibition centre

From the Cable&Wireless node in Amsterdam, KPN (managed by Cable&Wireless) carried the GbE on a dedicated wavelength in a point-to-point metro DWDM system to the RAI exhibition centre.

The red line in *Fig. 11* shows a high-level view of the Primary route for the circuit between London Broadcasting House and the RAI in Amsterdam.

From Broadcasting House to Telehouse in Docklands, Cable&Wireless utilised the “Raman Network” provided for Siemens and the BBC. This is an extremely high-capacity dense wave-division-multiplexing (DWDM) network built to accommodate the BBC’s requirements for the next ten years. It is capable of providing multiple 10 Gbit/s links from all of the major BBC regional studios to two central nodes. This allows services to be connected between any BBC sites via just one optical-to-electrical-to-optical (OEO) conversion. The optical backbone is based on Raman amplification rather than erbium-doped fibre amplification (EDFA). This provides up to 240 10 Gbit/s wavelengths on each core network link.

Broadcasting House has three 10 Gbit/s connections on each of two diverse paths to the central Raman nodes. In normal day-to-day operation, these links carry multiple data services, network radio, PAL and digital television distribution as well as multiple audio and 270 Mbit/s SDI video contribution circuits.

The GbE was mapped across the Raman network and delivered to Cable&Wireless International Core Director network in London. The GbE was protected across the Raman network at the sub-network connection level (SNCP). This meant that should there be a failure within the network, the GbE would switch to its “protection” route in around 20 ms.

The Cable&Wireless Core Director network is a self-healing transport network, currently consisting of 30 nodes linking major cities in Europe, the USA and Asia. This network provides multiple protection paths and diverse routing options for any bandwidth up to STM-64 (10 Gbit/s). In the event of a network failure, the Core Director network automatically calculates and deploys the most appropriate protection path. This ensures that even with multiple failures, traffic is restored.

From the Cable&Wireless node in Amsterdam, the GbE was handed to a KPN GbE tail circuit into the RAI exhibition Centre. This was designed with 1+1 fibre resilience, and would automatically switch to the reserve route in the event of a fault.

A key point to note is that this demonstration used “standard” telecommunication network equipment and interfaces, configured in a standard manner. Although dedicated international Gigabit Ethernet links are likely to be an extravagant use of network resource for the time being ... this could well change in the future.

London-Amsterdam link in operation

In order to demonstrate the live nature of the link, the scenario set up was to emulate live news reports from London to Amsterdam with two-way interaction between a reporter on the balcony of City Hall in London and a presenter in the SHV Theatre in Amsterdam. This report from London was inserted into a 25-minute show about Super Hi-Vision in the theatre, narrated by the presenter [9][10].

The first demonstration was a press launch, just before the exhibition opened, with Maggie Philbin (a BBC Tomorrow’s World presenter) as the presenter, and Erik Huggers (Director of BBC Future Media and Technology) as the reporter. *Fig. 12* shows Erik as he was viewed on the 6m-wide screen



Figure 12
First live SHV report from London by Erik Huggers

in the SHV Theatre. After a short conversation between Maggie and Erik, the SHV camera panned away from Erik to view the scene across the river, including the Tower of London, and then settle on a view of Tower Bridge. A member of the audience was then invited to choose a detail in the scene into which the camera would then zoom.

The show was repeated every 25 minutes using other presenters and reporters during the course of the IBC exhibition. In addition, the pictures and sound were shown continuously on a 4k LCD monitor and a pair of speakers on the outside of the theatre for casual visitors to view.

The received picture quality was excellent, enabling the fine details of the scene, including Tower Bridge and people, to be picked out clearly. *Fig. 13* shows a photo of Tower Bridge taken from the theatre screen, but it is difficult to convey the details viewable in this reproduction.



Figure 13
Tower Bridge as viewed on SHV

The 3D surround sound quality was completely convincing; ambient sounds of London and the river were reproduced effectively, even the sounds of airplanes and helicopters flying overhead sounded as if they were flying over the theatre. Occasionally a demonstration session coincided with Tower Bridge opening to let a ship pass through, where the audience's ability to look at different parts of the picture in their own time, showed the benefit of the SHV system to convey a feeling of presence. This, along with the surround audio in the theatre, gave an immersive experience for the audience. This was particularly effective during the River Festival held on the weekend, with its sights and sounds.

No bit errors were detected on the link over the five days of the exhibition. At one time, the picture froze due to a coder lock-up, but this was quickly solved by resetting that coder. There was a transmission delay, mainly due to the video codecs; it was comparable with that from a satellite link, but it was less noticeable than usual during the conversation between the reporter and the presenter, because viewers were engrossed in looking at the details in the scenes. This high level of immersion on a 6m-wide screen, viewed at less than one picture height, meant that we had to be careful to pan the camera slowly to avoid the audience feeling unbalanced or nauseous. This is an indication that a new production grammar might be more appropriate for SHV programmes.

Dirac SHV

If SHV is to become the next-generation television service, it must be practicable to deliver it to the home at reasonable bitrates. A likely target for SHV video bitrates to the home is around 65 Mbit/s, allowing SHV to be delivered within a single 70 Mbit/s satellite transponder. This is significantly lower than the bitrates achieved so far using the experimental NHK H.264 hardware system, and is equivalent to an HDTV bitrate of just 2 Mbit/s if full 8K SHV is to be delivered. It is likely that compression technology at least twice as efficient as the current state-of-the-art may ultimately need to be developed to achieve this.

For this reason, the BBC and NHK are collaborating on developing next-generation compression technology for SHV. So far, work has focused on developing the BBC's Dirac compression system for SHV coding. The results of these experiments were demonstrated by the BBC alongside the London-Amsterdam transmission test at IBC.

Dirac technology

Dirac was developed as a royalty-free codec [11] yet, despite that, it has offered highly competitive performance compared with H.264, especially at higher resolutions. Dirac has a full specification [12] and currently the intra-coding elements are being standardized through the SMPTE as VC-2 [13].

Dirac is a conventional hybrid codec, with a transform stage applied both to pictures (Intra frames) and motion-compensated difference pictures (for Inter frames). However, Dirac uses two technologies that provide effective scaling across resolutions.

The first of these is the use of the *wavelet transform* in place of the usual block transform. This iteratively applies successive pairs of low-frequency and high-frequency filters, vertically and horizontally to represent pictures using a succession of subbands of increasing resolution (Figs 14 and 15). At each level, only the Low-Low subband is further decomposed, meaning that high-frequency information is captured using relatively short filters, and low-frequency information with

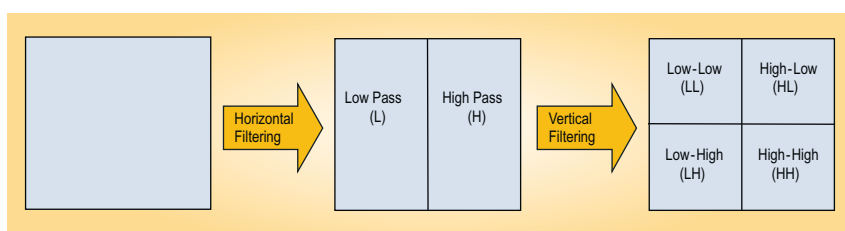

Figure 14
A single DWT filtering stage

with relatively long filters.

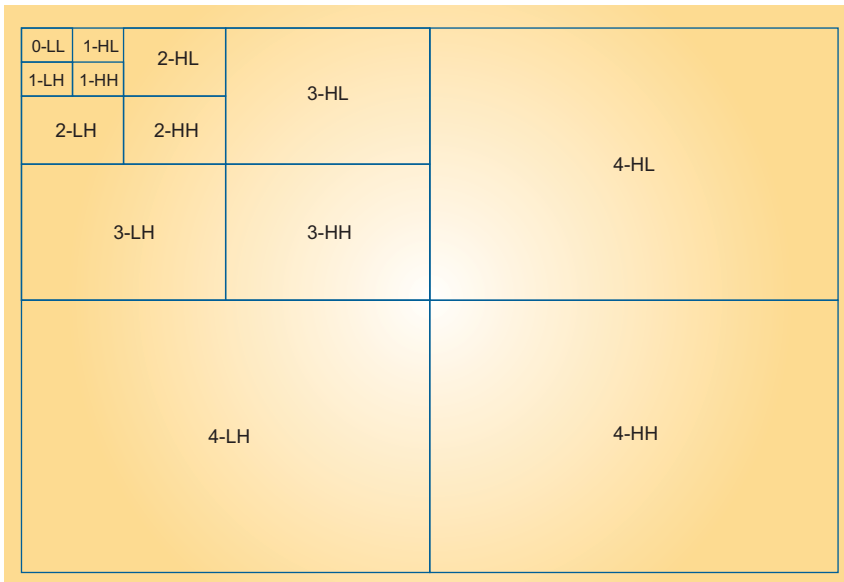

Figure 15
Identification of the subbands of a 4-level wavelet transform based on repeated filtering

longer filters, greatly reducing the ringing artefacts.

The other tool that is available in Dirac is motion compensation using variable-sized overlapped blocks. By avoiding using a block transform, there is no need to match block size to a transform dimensions: all that is required is that block edges are minimized, which is achieved by overlapping block predictions with a linear weighting matrix (*Fig. 16*). This means that block sizes can be chosen appropriately for the dimensions of the video, with much larger block sizes for SHV, thus greatly reducing the motion data bitrate.

Dirac experiments

The Dirac experiments consisted of determining the optimum coding parameters for SHV coding. Wavelet depths of 4 or 5 were used and block sizes were 36x36 overlapped at a 24x24 separation (50% overlap). Another factor was the most appropriate GoP structure. An IB BBBBP structure was used, with a GoP length of 1 second, with each B-frame also used as a reference for the succeeding B-frame.



Figure 16
A variable-sized linear weighting matrix is used for overlapped block motion compensation to reduce block artefacts

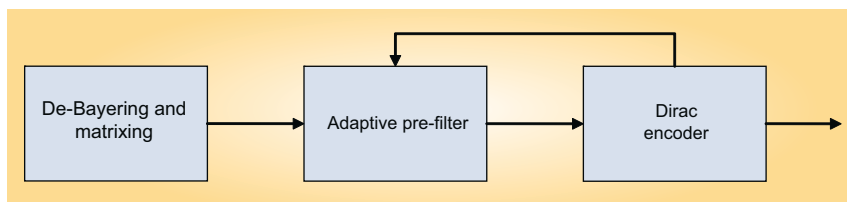

Figure 17
Simulation architecture

It was decided to perform simulations on full SHV – 7680 x 4320 pixels at 60 frames/sec – rather than the quincunx-sampled format used for the transmission test. This involved applying a non-linear de-Bayering filter and matrixing to produce full resolution YC_bC_r data with 4:2:0 chroma sampling.

The overall simulation architecture is shown in *Fig. 17*.

It was discovered that the sample video, produced by the first-generation SHV experimental camera, was very noisy for low-light sequences and also contained a number of artefacts traceable to sensor errors in the camera. This necessitated the use of an adaptive pre-filter to control the amount of noise in high-frequency subbands, requiring a large amount of bitrate to code.

With this architecture in place, further experiments were performed to adjust the perceptual weighting and quantization strategy used at the encoder.

The result of the experiments was very good quality at 128 Mbit/s on the test material. For the most part, the material did not exhibit large motions, but some (especially the Sunflower sequence) was quite challenging. Visible artefacts were seldom present, with pictures tending to become soft in the more difficult sections. Given the very high initial resolution, this is a welcome characteristic.

Further developments

The experiments established that Dirac could be a basis for a successful SHV coding system. However, to meet the very challenging bitrate targets for SHV delivery, significant advances in fundamental compression technology are required. Although future SHV cameras are likely to have much better noise performance, significant input noise is likely to be a continuing problem for SHV compression systems. To this end, a wavelet system may require modification to give finer frequency selectivity to aid in noise reduction. Although Dirac uses scalable components, it is not a fully scalable technology, and a resolution-scalable solution may prove the most attractive in the longer term.



Figure 18
The SHV team at London City Hall

Future work

In this transmission demonstration, the GbE circuit was set up with the whole capacity reserved for the signal – with no third party traffic from other customers of the telecoms provider sharing that path. Although the demonstration did include non-SHV traffic on the same link, this traffic was carefully controlled so as not to interfere with the SHV traffic. Therefore, the next step would be to transmit the SHV traffic on an unsynchronized IP network, together with third-party traffic, to investigate the issues of contention, packet loss, jitter, etc. We can then develop an error correction scheme best adapted to the SHV signal, plus set appropriate transmission parameters and design a monitoring policy. This work should be applied to standardization for the successful exchange of SHV content between broadcasters.

Regarding video and audio compression, it is still early days. The potential correlations in the 22.2-channel audio suggest potential savings by using some form of joint coding. The much higher quality in an SHV picture suggests a compression efficiency benefit would be obtained from a specifically-adapted coding scheme. There have been indications of this from the early work of applying Dirac coding to SHV. This work should be continued to study new coding ideas to further improve performance and submit the results for standardization.

Conclusions

Ultra-broadband networks are becoming more widely available, and thus this demonstration shows the possibility of Super Hi-Vision live content being relayed from virtually anywhere in the future. We have confirmed the capability of the currently-available networks through this experiment, by showing that transmitting the SHV signal across international borders and between different network operators is not a problem.

The bitrate of 650 Mbit/s using MPEG-2 is higher than desired and so further work is needed to improve the new Dirac-SHV video coding efficiency and to investigate the effects of SHV signals operating within fully-contended public telecoms networks. Further work on improving the transmission and coding of SHV should be standardized to allow successful exchange of SHV content between broadcasters.



John Zubrzycki is the Media Fundamentals Portfolio Manager at BBC Research & Development, in charge of a team working on “Beyond HD” projects, including Ultra High Definition Television (in collaboration with NHK), High Frame Rate TV and 3D-TV (in the 3D4You European research project).

Mr Zubrzycki joined BBC Research in 1982 and worked on a wide range of projects including dense-WDM fibre-optic studio networks and 4th generation mobile technology. He led the R&D team that produced the world's first digital radio camera in 2000. He was also responsible for the development and testing of the terrestrial STBs used in the BBC HDTV trials before turning his attention to what might be “Beyond HD”.

Dr Thomas Davies is a Lead R&D Engineer at BBC Research & Development. He was the lead algorithm developer behind the Dirac video compression system, and is responsible for next-generation video compression research, especially in the context of future television systems such as SHV. He joined the BBC in 2000 after gaining a Ph.D. in Mathematics and spending a period in consultancy, working on satellite communications and networking. In addition to video coding, his work at the BBC has included digital radio cameras, advanced OFDM modulation and error-control coding, as well as video quality assessment studies.



After many years in the BBC, **Peter Calvert-Smith** has been with Siemens since the sale of BBC Technology. Recent work has included the specification and assessment of desktop production technology and, as a technical architect on the BBC Scotland Pacific Quay project, making assessments of both conventional video and file-based production tools.

At present, Mr Calvert-Smith is working on projects for the delivery of Audio/Video over IP for Siemens' clients. His primary responsibility is specifying and measuring the delivered media quality.



Paul Styles joined Cable&Wireless in 2005 through its acquisition of Energis where he had worked on the network supporting the BBC since 1998, when Digital Television was launched in the UK. His current role is as a Solution Design Consultant and he has a particular interest in meeting the unique needs of the Broadcast Industry through the use of “standard” telecoms networks.

Mr Styles was instrumental in the design and deployment of the “Raman” high capacity network, recently deployed for Siemens to support the BBC.



Bill Whiston joined BBC Television in September 1970 and BBC Outside Broadcasts in 1978, becoming a Sound Supervisor in 1984. He joined SISLive in April 2008.

Mr Whiston has been involved in a whole range of programmes covering all aspects of Outside Broadcasts, ranging from major events such as Royal Funerals, Weddings and the Queen's Golden Jubilee to Drama, Natural History, Sport (Wimbledon and two Olympics) and Classical Music (BBC Proms). He first became interested in multi-channel sound in the mid 1990s and has been at the forefront of the BBC's development of its HD/5.1 services since then. He is a member of the EBU's EHDF sub-committee on multichannel standards and development in audio for HD transmission in Europe.

Yukihiro Nishida is Senior Research Engineer, Human & Information Science, at NHK Science and Technical Research Laboratories in Tokyo. He has been involved in many areas of broadcasting technologies including HDTV, digital broadcasting, video coding, multiplexing and quality evaluation. One such area is the development of the Super Hi-Vision transmission system described in this article. He is also active in the standardization of broadcast technologies in ITU-R, ARIB and the EBU.

Mr Nishida is Vice-Chairman of ITU-R Study Group 6 on broadcasting services, and is also Chairman of Working Party 6B covering source coding, interfaces, multimedia and interactivity. He graduated from Keio University, Japan, with an M.Sc. in Electrical Engineering.



Masaru Kanazawa received his B.Sc., M.Sc. and Ph.D. degrees in Electronics from Hokkaido University in 1977, 1979 and 2004. From 1979, he has been working for Japan Broadcasting Corporation (NHK) and is currently an executive research engineer at NHK's Science and Technical Research Laboratories, engaged in the development of extremely high resolution imagery systems.

Dr Kanazawa is a member of the Institute of Electronics, Information and Communication Engineers of Japan (EIC), the Institute of Image Information and Television Engineers of Japan (ITE), and of SID.

This experiment has shown that the combination of ultra-high-resolution images with multichannel sound, shown live on a large screen with a 22.2-channel sound system, gives the audience the most immersive viewing experience that is practical without wearing a headset – it is completely different from normal TV viewing. Programme-makers will be able to take pictures from virtually anywhere in the world and try innovative new production techniques in order to make the most of this exciting new medium.

References

- [1] ITU-R BT.1769 (2006): **Parameter values for an expanded hierarchy of LSDI1 image formats for production and international programme exchange**
- [2] SMPTE 2036-1-2007: **Ultra High Definition Television - Image Parameter Values For Program Production**
- [3] SMPTE 2036-2-2008: **Ultra High Definition Television - Audio Characteristics and Audio Channel Mapping for Program Production**
- [4] H. Shimamoto et al: **An 8k x 4k Ultrahigh-Definition Colour Video Camera with 8M-Pixel CMOS Imager**
SMPTE Motion Imaging, July/August 2005, pp. 260-268
- [5] R. Funatsu et al: **An HDTV image generator in Super Hi-vision system for HDTV program production**
2008 ITE annual convention, 4-4
- [6] M. Kanazawa et al: **An ultrahigh-definition display using the pixel-offset method**
Journal of SID, 2004, Vol. 12, No. 1, pp. 93~104
- [7] E. Nakasu et al: **Technical development towards implementation of extremely high resolution imagery systems with more than 4000 scanning lines**
IBC-2006 Conference Publication, pp. 345 to 352
- [8] Y. Nakayama et al: **Live production and transmission of large-scale musical TV program using 22.2 multichannel sound with ultra-high definition video**
IBC-2007 Conference Publication, pp. 253 to 259.
- [9] NHK article on these IBC demos : http://tech.ebu.ch/docs/techreview/trev_2009-Q0_SHV-NHK.pdf
- [10] RAI article on these IBC demos : http://tech.ebu.ch/docs/techreview/trev_2009-Q0_SHV-RAI.pdf
- [11] T. Borer, T. Davies and A. Suraparju: **Dirac Video Compression**
Proc. IBC, Sept. 2005
- [12] Dirac Specification: <http://www.diracvideo.org/specifications>
- [13] SMPTE S2042 (CD): **VC-2 Video Compression**

Super Hi-Vision

— delivery perspectives

Alberto Morello and Vittoria Mignone

RAI Research and Innovation Centre

Kazuyoshi Shogen and Hisashi Sujikai

NHK Science & Technical Research Laboratories

Super Hi-Vision – the 4320 line x 7680 pixels/line TV system under development by NHK, the Japanese public broadcaster – offers an astonishing user experience, thanks to a picture resolution which is sixteen times that of what we presently call ‘High Definition’ (HDTV). There are 60 progressively-scanned frames every second and, for the audio, 22.2 three-dimensional surround channels – nine at ceiling height, including one directly overhead; ten channels at the centre height of the screen; three front channels at floor level and, for the rolling thunder and other low-frequency effects, two channels at the front.

Since the bitrate of the native Super Hi-Vision signal is a massive 24 Gbit/s, the major part of the technical challenge is in developing ways of delivering the service to the final user. One of the highlights of IBC-2008 in Amsterdam was the first live transmission of Super Hi-Vision from the RAI Research uplink station in Turin to Amsterdam, via a Eutelsat Ku-band satellite using DVB-S2.

This article summarizes the studies under development at the NHK Laboratories and at the RAI Research Centre ... towards the evaluation of various SHV delivery systems, via both satellite and terrestrial broadband channels.

SHV compression

Since Super Hi-Vision (SHV) has an intrinsic resolution that is 16 times larger than HDTV, a proportionally higher bitrate should be used, further increased by the progressive scanning format. NHK tests demonstrated that, when using 16 x MPEG-4 AVC encoders, the required final audio-video bitrate ranges from 140 to 160 Mbit/s. Further progress is expected to be made in picture-coding efficiency over the next decade and, thus, a transmission bitrate of about 80 Mbit/s is assumed in the examples described in this article.

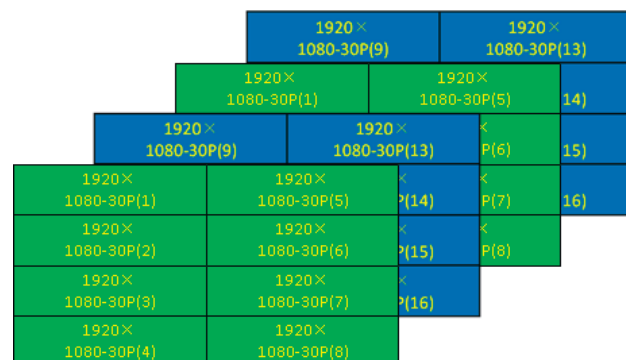

Figure 1
Divided SHV images (16 HDTV Images are processed by 16 HDTV encoders)

The current NHK real-time codec prototype consists of 16 encoders and decoders, using H.264 [1]. The SHV image is divided into 16 HDTV pictures, eight in the spatial dimension and two in the time (temporal) dimension (*Fig. 1*), each one being processed by a single H.264 HDTV encoder.

SHV delivery by satellite

Ku band

SHV delivery to the home is possible today, using state-of-the-art technologies such as high-power Ku-band satellites and DVB-S2 modulation formats. This was demonstrated by the joint NHK-BBC-RAI presentation at IBC-2008 in Amsterdam [2][3], where the SHV signals were delivered from the uplink station at the research headquarters of Italian public broadcaster RAI in Turin, over Ku-band satellite capacity provided by Eutelsat.

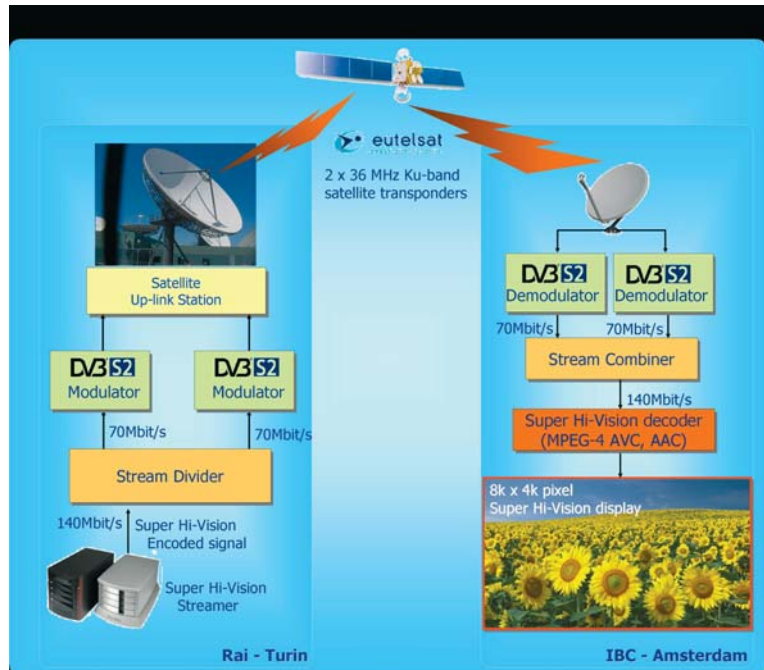

Figure 2
The SHV international transmission at IBC-2008

For this first public demonstration of Super Hi-Vision by satellite, it will come as no surprise to discover that DVB-S2 technology [4] was selected by RAI, who led the development of this second-generation DVB system in 2003. Thanks to this state-of-the-art system, recognized by the ITU as a worldwide standard for digital satellite broadcasting, the theoretical Shannon limit is approached within less than one decibel in the case of a linear channel.

In order to accommodate the 140 Mbit/s SHV signal in a 72 MHz satellite bandwidth, a symbol rate of 60 Mbaud may be adopted with 20% roll-off, combined with 8PSK modulation and rate 5/6 LDPC FEC coding, for a total required Signal-to-Noise power ratio (SNR) of around 10 dB including satellite distortions.

As shown in *Fig. 2*, a slightly different configuration was adopted at IBC-2008 for practical reasons (e.g., the lack of very high symbol-rate DVB-S2 demodulators). The SHV signal was split into two 70 Mbit/s MPEG Transport Streams, transmitted over two 36 MHz satellite transponders, and re-combined at the receiver using the synchronization and de-jittering features of DVB-S2 in the Adaptive Coding and Modulation (ACM) mode.

The Eutelsat satellite – Atlantic Bird 3 at 5°W – was used, offering a high EIRP (53 dBW) superbeam (*Fig. 3*) over central Europe, Italy and Spain, where SHV can be received with a consumer-type 80 cm antenna (leaving a 4 dB clear-sky margin).



Figure 3
The Eutelsat Atlantic Bird Superbeam coverage

Perspectives for the use of the Ka band

As the Ku band is already highly used today for many services, other frequency resources may be investigated for a future comprehensive multi-programme SHV service. An analysis of the satellite

Ka band (21.4 - 22.0 GHz), that was allocated to broadcasting services in Regions 1 and 3 during the WARC-1992 conference in Torremolinos, is in progress in the research labs of broadcasters, starting from the early studies already published in EBU Technical Review [5][6].

We are now taking into consideration some additional sophisticated technologies to help overcome the high rain attenuation in this band. These are for example:

- **dynamic power control** on the satellite [7];
- **multi-spot coverage** combined with **Adaptive Coding and Modulation** (ACM) or;
- **Scalable Video Coding** (SVC) combined with **Variable Coding and Modulation** (VCM).

It should be noted that ACM and VCM are already included in the DVB-S2 system, and SVC profiles are included in MPEG-4 AVC coding.

The Ka band for broadcasting allocates 600 MHz over two polarizations. Hence, for example, 24 SHV programmes at 82 Mbit/s may be allocated per service area, assuming the use of DVB-S2 parameters (see Fig. 4):

- 8PSK 2/3 modulation/coding;
- symbol rate = 41.4 Mbaud;
- total bandwidth BW = 49.7 MHz
- required SNR of around 8.6 dB, with 1 dB implementation margin and 1 dB of channel distortions).

In order to guarantee service availability for 99.9% of the time, we can assume for example that 13 dB of clear-sky margin is required [8]. For precise computations, the specific rain statistics for a given country have to be considered, leading to a required clear-sky SNR = 21.6 dB in a noise bandwidth of 41.4 MHz.

In the event of broadband modems being devised, picture coding might benefit from statistical multiplexing (e.g., BW = 200 MHz, four SHV programmes per bouquet).

NHK studies on dynamic power control and shaped antenna beams on board the satellite

NHK has developed prototypes of a 300 MHz wideband modulator and demodulator. The broadcaster has carried out an indoor Super Hi-Vision transmission experiment through the 21 GHz band experimental transponder, via a single carrier, to verify the performance of the hardware and evaluate the wideband transmission characteristics [9]. The equipment used for the transmission experiment is shown in Fig. 5. The signal from the Super Hi-Vision encoder was modulated, up-converted to a 21 GHz band signal and amplified by a miniature Travelling Wave Tube (TWT) which simulates a transponder in the broadcasting satellite. The modulated signal was radiated

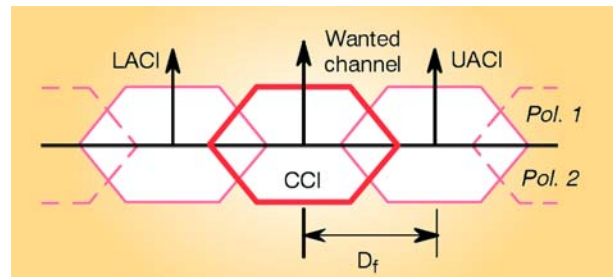

Figure 4
Example of channel configuration of the 600 MHz broadcasting Ka band

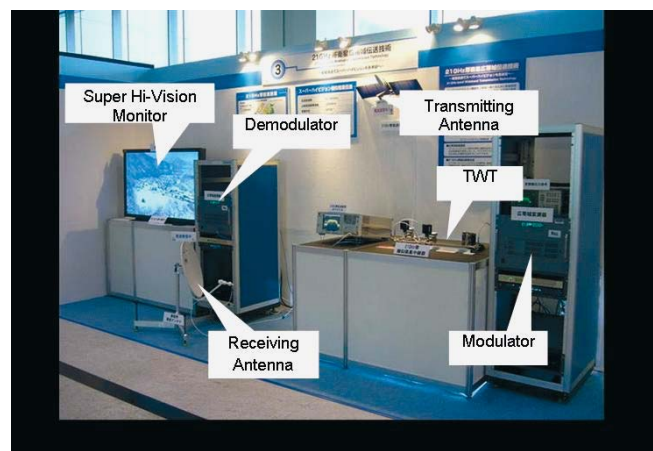

Figure 5
Indoor transmission experiment of SHV using the 21 GHz frequency band

Table 1
Transmission parameters

Centre frequency	21.85 GHz
Modulation	QPSK
Symbol rate	250 Mbaud
Occupied Bandwidth	295 MHz
Information Rate	500 Mbit/s

from a horn antenna and after going through the air, it was received by a parabolic broadcasting antenna whose diameter was equal to a typical home satellite antenna, i.e. 45 cm in diameter.

The modulation parameters are indicated in *Table 1*. Through the experiment, NHK confirmed the possibility of broadcasting the Super Hi-Vision signal via a 21 GHz band satellite.

In 2009, NHK plans to perform a transmission experiment with Super Hi-Vision, using the WINDS (Wideband InterNetworking engineering test and Demonstration Satellite) that was launched in Japan during February 2008.

The 21.4 - 22.0 GHz band, however, suffers from large rain attenuation [8]. Consequently, we have been studying rain-fade mitigation techniques, in which the radiation power is increased locally in the area of heavy rainfall (“boosted” beam) while keeping the “nationwide” beam with the same frequency by using an onboard phased array antenna (see *Fig. 6*).

Fig. 7 shows an example of a phased array antenna and its radiation pattern. The antenna boosts the beam radiation power in areas suffering from heavy rain-fall [10].

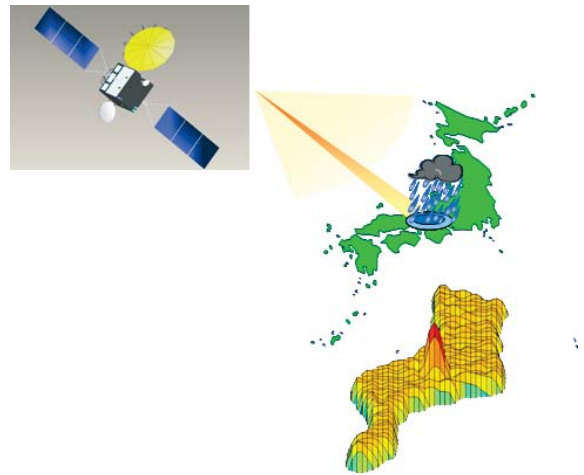

Figure 6
Compensation of rain attenuation by using a phased array antenna

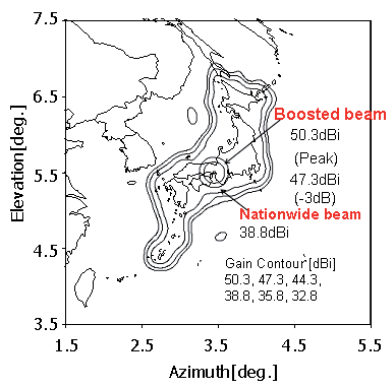
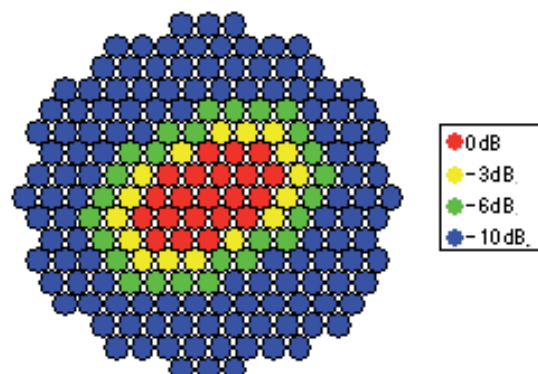
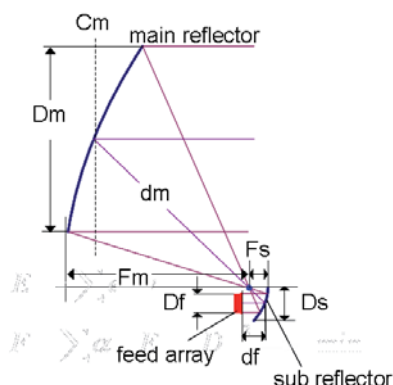

Figure 7
Example of a phased array antenna and its radiation pattern

Left: Radiation pattern
Bottom Left: Structure of antenna
Bottom Right: Feed array and the feed power distribution



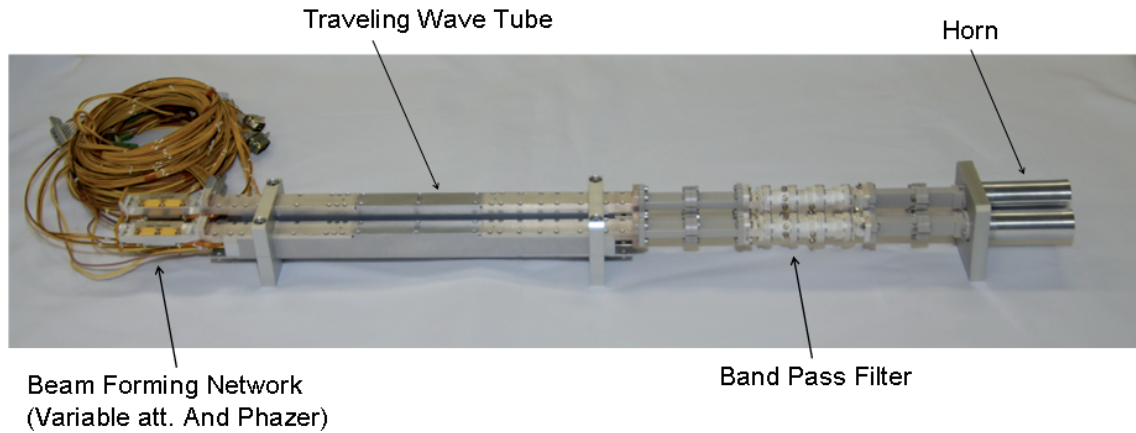

Figure 8
Part of the feed array (3 horns) for the 21 GHz satellite-broadcasting band

Fig. 8 shows part of a feed array (3 horns) for the 21 GHz satellite-broadcasting band. It consists of a beam-forming network, a TWT [11], a band-pass filter and a horn.

Rai studies on ACM and VCM modulation techniques

The examples given in the following sections are not the result of detailed optimizations nor specific proposals for real services, but they are intended as preliminary exercises to assess the potential of the proposed technologies and the use of the Ka band for SHV.

The examples given here are based on the DVB-S2 characteristics described in ETSI EN 302 307, and summarized in *Table 2*. For the sake of simplicity, a 1 dB implementation margin and 1 dB satellite distortion are assumed in the examples, for any transmission mode.

Table 2
Required SNR and spectrum efficiency for various DVB-S2 modes

DVB-S2 mode	Required SNR (dB)	Spectrum efficiency
QPSK 1/4	-2.35	0.490243
QPSK 2/5	-0.30	0.789412
QPSK 1/2	1.00	0.988858
8PSK 2/3	6.62	1.980636
8PSK 5/6	9.35	2.478562

ACM and multi-spot coverage

As a countermeasure against heavy rain attenuations at Ka band frequencies, RAI analyzed a multi-spot country coverage approach, combined with Adaptive Coding and Modulation.

Let us assume that the total number of spots per country is N , and each spot uses a different frequency to avoid interfering with the adjacent spots (thus reducing the spectral efficiency of the plan by a factor of 3 or 4). Furthermore, it is assumed that within the service area there is a wide-spread network of rain-attenuation sensors, which could be implemented by connecting all user receivers with a feedback channel carrying real-time information on the reception margin (in ten years time, the availability of hybrid broadcast-broadband receivers is highly probable, thus this

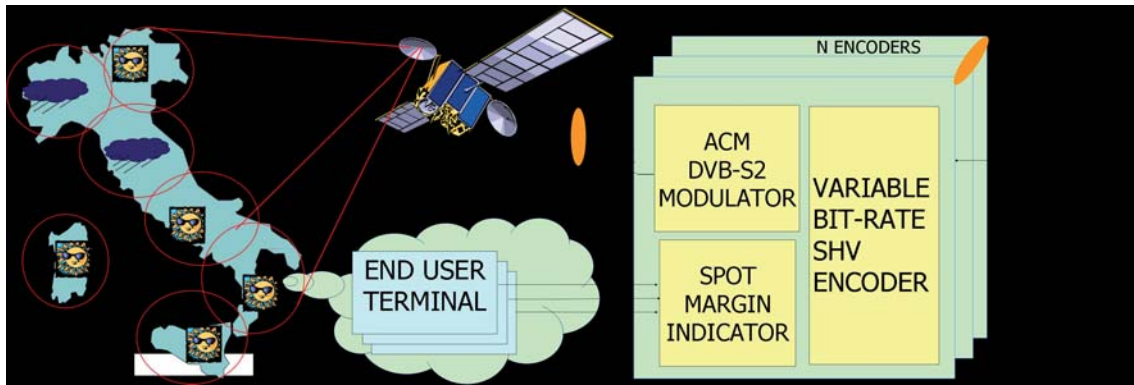

Figure 9
Multi-spot coverage and adaptive coding and modulation scheme

approach may become much more viable than it is today). This feedback information may be collected and aggregated to produce an “effective margin indicator” for each spot.

As widely described in the literature [12], Adaptive Coding and Modulation is a technique which may be used as a powerful countermeasure against rain fades: when signal attenuations occur, the source bitrate is reduced using a closed-loop feedback (thus reducing the picture quality) and the remaining capacity is exploited by selecting a more robust channel coding and modulation format, as depicted in *Fig. 9*.

The local nature of heavy rain attenuation ensures that the percentage of affected areas decreases when increasing the total number of spots.

In the scenario described, further studies are required to evaluate the service continuity versus the clear-sky margin, taking into account the spot dimensions and the different ways of computing the “effective spot margin”. In the best case of very small spots, the service continuity can be computed as for a single reception point; this simplification will be adopted in the following example.

In order to assess the potential of this approach, let us assume that full-quality SHV is guaranteed for 99% of the year (about 4 dB clear-sky margin) and ACM is used to maintain service continuity for 99.9% of the time (about 9 dB of additional SNR variations). Let us for example use DVB-S2 8PSK 5/6 to transport 82 Mbit/s SHV. To cope with a further SNR variation of 9 dB, we can select the DVB-S2 mode QPSK 2/5, offering a capacity of 26.11 Mbit/s. To satisfy service quality targets, we need to design the satellite link budget for a clear-sky SNR of 15.35 dB in a noise bandwidth of about 33 MHz, and the required total bandwidth per SHV programme is about 40 MHz. In the total available bandwidth of 600 x 2 MHz, we can allocate around 30 carriers, but 3 to 4 different frequencies need to be used to avoid inter-spot interference, resulting in 7 to 10 available SHV programmes per location.

Scalable Video Coding and VCM

Another approach to overcome heavy rain attenuation in Ka band may be to combine Scalable Video Coding and Variable Coding and Modulation (VCM) as provided by DVB-S2. This approach was already proposed in the early 90s for digital TV/HDTV broadcasting over terrestrial and satellite channels, but it did not find consensus due to the less demanding transmission environments and the inherent complexity.

While ACM is dynamically controlled by reception conditions at the receiver, VCM is static and does not require any feedback from the receivers. In this approach, the video signal comprises:

- a) a **high-priority stream** which is permanently associated with a highly-protected modulation and coding format, and;
- b) a **low-priority stream** that is associated with a high-efficiency format.

When reception conditions at a given location are good, both streams are correctly demodulated and jointly decoded to provide the full SHV quality. On the other hand, when reception conditions are bad, only the high-priority stream can be correctly demodulated, and the decoder passes on a scaled-down version of the picture (in terms of resolution and/or coding noise).

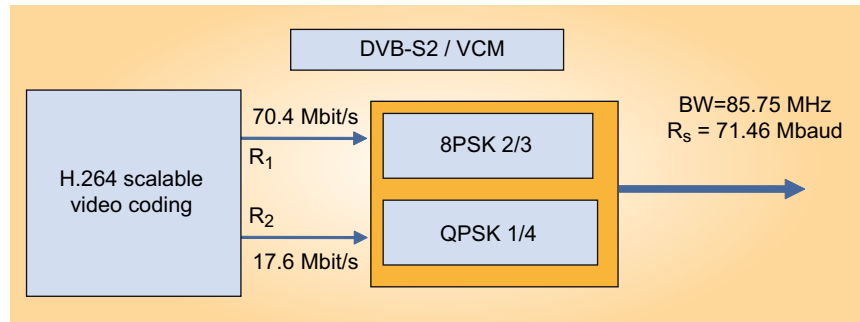

Figure 10
Example of a VCM scheme for SHV

In order to assess the potential of this approach, let us use an example in line with the ACM case. Assuming, as in the previous ACM example, that full-quality SHV is guaranteed for 99% of the year (about 4 dB clear-sky margin) while VCM is used to maintain service continuity for 99.9% of the time (about 9 dB of additional SNR variations). The low-priority + high-priority bitrate is assumed to be 88 Mbit/s, 6 Mbit/s more than in the case without SVC. We further assume that this capacity is split into $R_1 = 70.4$ Mbit/s for low-priority and $R_2 = 17.6$ Mbit/s for high-priority (see Fig. 10). We use DVB-S2 8PSK 2/3 and QPSK 1/4 to achieve about 9 dB SNR difference between the high-priority and low-priority streams. The bandwidth occupation per carrier is the weighted sum of the bitrates over the spectrum efficiency of each mode:

$$BW = (R_1/1.9806) + (R_2/0.490) \times 1.20 = 85.75 \text{ MHz}$$

In conclusion, we need to design the satellite link budget for a clear-sky SNR of 12.62 dB in a noise bandwidth of 71.46 MHz ¹.

In the total available bandwidth of 600 x 2 MHz, we can allocate 7 x 2 carriers. This solution may be easily combined with the dynamic satellite power-control techniques under study at NHK, thus reducing the SNR difference between high-priority and low-priority streams and improving the spectrum efficiency.

In the previous example, a large part of the bandwidth occupation is associated with the high-priority stream, using a very low code-rate, and this also penalizes the power requirements for the low-priority stream. In order to achieve the same 99.9% service availability using QPSK 1/2 for the high-priority stream, 2.1 dB of additional satellite EIRP would be required, but the spectrum efficiency would be significantly improved (BW = 64.02 MHz, corresponding to 22 SHV programmes instead of 14 in the 600 x 2 MHz Ka band).

Comparing the two solutions, ACM and VCM, the first approach requires less bandwidth per carrier (about half in the examples) for similar satellite power per programme, but the capacity loss due to the multi-spot configuration heavily penalizes the ACM approach (7 to 10 SHV programmes versus 14). Regarding the overall quality of service, the examples show a higher picture quality when using ACM at service threshold (26 Mbit/s versus 17.6 Mbit/s), but this has to be confirmed by a more precise evaluation of service availability. This first comparison seems to indicate that the ACM approach is less attractive, also taking into account its global complexity which includes:

- a direct feedback from users, for measuring the local reception margin in real time;
- a more sophisticated terrestrial head-end ... and last but not the least;
- a complex satellite multi-spot architecture.

1. It should be noted that this corresponds to an SNR of 15.96 dB in the noise bandwidth of 33.08 MHz of the ACM example and, therefore, the two methods are well aligned (within 0.6 dB) in terms of satellite power requirements per SHV programme per country-wide coverage.

Let us now compare VCM with the conventional approach using 8PSK 2/3 without ACM/VCM (requiring a clear-sky SNR = 21.6 dB in a noise bandwidth of 41.4 MHz). In the conventional approach, the satellite power requirements per programme would be significantly higher (6.6 dB in the examples) than for VCM, with a better bandwidth exploitation (24 SHV programmes instead of 14 in the VCM approach). Instead, by trading off capacity versus ruggedness in the conventional approach through using QPSK 1/2, the satellite power requirements would decrease by 2.6 dB (i.e., 4 dB more than the VCM solution) and the number of SHV programmes would decrease to 12 (compared with 14 programmes in the VCM solution).

As a last synthesis from the Ka band examples, we may extrapolate that the VCM approach offers around 5 dB gain in satellite power requirements for the same number of SHV programmes and service availability (target: 99.9% of the year), but at the cost of a significant reduction in picture quality for around 1% of the time.

SHV delivery via terrestrial channels

DVB-T2 is the second-generation digital-delivery system over terrestrial VHF/UHF channels. It was recently developed by DVB [13] and allows for a variety of modulation and coding rates, with capacities up to 33-35 Mbit/s and a minimum SNR of about 16 dB (+2 dB implementation margins), assuming the use of directional receiving antennas. It is based on OFDM, with up to 32k multicarrier modulation and the same state-of-the-art LDPC coding as in DVB-S2.

The system's configuration flexibility allows us to devise modulation and coding modes which offer higher capacities, provided that the SNR is sufficiently high: if a 2 - 3 dB increase in SNR is available in the coverage area, the capacity can reach 37 - 39 Mbit/s. This capacity is however incompatible with the estimated full SHV bitrates to be delivered via terrestrial channels and, therefore, the development of a scaled version of SHV seems advisable.

As a first rough estimation, a 4k TV system should require 1/4 of the full SHV bitrate – down from 40 Mbit/s with current MPEG-4 encoding to 20 Mbit/s with future-generation coding. Furthermore, DVB-T2 implements VCM, thus offering the possibility of differently protecting the various signals to be transported; this allow us to think of possible solutions combining SVC and VCM – also for the terrestrial environment.

Conclusions

The challenges facing SHV are manifold, ranging from production requirements to the type of display required by the end-user. For signal delivery, the IBC-2008 demonstration has already shown that 72 MHz Ku-band satellites and state-of-the-art transmission technologies such as DVB-S2, can today deliver SHV by satellite to the home, using reasonably-sized receiving antennas. Unfortunately, the Ku-band is already widely used today for many services.

This article has investigated the possible use of the satellite Ka-band, allocated to broadcasting services in 1992, for SHV delivery. This is made possible, thanks to the implementation of sophisticated technologies to overcome the high rain attenuation that affects signal propagation in this band. Such technologies include dynamic power control and shaped antenna beams on board the satellite, and Scalable Video Coding combined with Variable Coding and Modulation (which is already included in the MPEG-4 coding scheme and DVB-S2 satellite transmission system).

Furthermore, delivery of SHV via terrestrial channels has also been considered here. The capacity offered by novel terrestrial broadcasting systems, such as DVB-T2, seems incompatible with the estimated full SHV bitrates required and, therefore, the development of a 4k TV system seems advisable.



Alberto Morello graduated in Electronic Engineering from the *Politecnico di Torino* in 1982, and took his doctorate degree in 1987. He joined the RAI Research Centre in 1985 and became its Director in 1999.

Dr Morello has been engaged in research on advanced digital modulation and coding techniques for television and sound broadcasting, and has participated in a number of European Research and Development Projects. He is author of technical/scientific articles in leading reviews such as IEEE Transactions and EBU Technical Review, and he regularly contributes to national and international Conferences.

Alberto Morello had a primary role in the RAI digital HDTV experiments via the Olympus satellite (Italia '90), and in the definition of the DVB systems for TV broadcasting by satellite and terrestrial channels (DVB-S, DVB-T and DVB-T2). Furthermore, he was Chairman of the DVB groups which defined the DVB-DSNG and DVB-S2 systems. Currently, he is Chairman of the EBU Technical Committee.

Vittoria Mignone received the *Laurea in Ingegneria Elettronica* degree from *Politecnico di Torino*, Turin, Italy in 1990.

In 1991 – in co-operation with the Electronics Department of *Politecnico di Torino* – she became engaged in studies of satellite broadcasting, on behalf of the National Research Council. Since 1992, she has been with the RAI Research Centre, involved in studies on the definition of the ETSI Standards for digital TV broadcasting by satellite, cable, terrestrial and DSNG. Her current activities are in the field of advanced digital modulation and channel coding techniques for satellite and terrestrial transmissions. She is the author of several technical papers.



Dr Kazuyoshi Shogen joined NHK (Japan Broadcasting Corporation) in 1979. In 1982, he moved to NHK's Science and Technical Research Laboratories to carry out research on broadcasting satellite systems, especially on contoured beam antennas for Japanese direct-broadcasting satellites. From 1998 to 2003, he worked in NHK's Engineering Administration Department, engaged in media planning and international affairs, and working with groups such as the ABU (October 1999 -), ITU-R (May 1995 -) and APT (December 1998 - 2003).

In 2003, Dr Shogen transferred back to NHK's Science and Technical Research Laboratories. Since then, he has become Chairman of the ABU Technical Committee (November 2006 -) and was a vice chairman of ITU-R SG6 WP6S (March 2002 - October 2007).

He is an IEEE Senior Member and is currently Director of NHK's Science and Technical Research Laboratories.



Hisashi Sujikai joined NHK (Japan Broadcasting Corporation) in 2001. He worked initially at the Engineering Administration Department, where he contributed to the planning and installation of NHK's TV networks and stations. In 2005, he transferred to NHK's Science and Technical Research Laboratories and has been engaged in research on advanced satellite broadcasting since then. He is now Principal Research Engineer in the Laboratories.



References

- [1] Shinichi Sakaida, Nao Nakajima, Kazuhisa Iguchi and Seiichi Gohshi: **Development of AVC/H.264 Codec System for Super Hi-Vision**
International Workshop on Advanced Image Technology 2008, p3-03, January 2008.
- [2] NHK article on these IBC demos : http://tech.ebu.ch/docs/techreview/trev_2009-Q0_SHV-NHK.pdf
- [3] BBC article on these IBC demos : http://tech.ebu.ch/docs/techreview/trev_2009-Q0_SHV-BBC.pdf

- [4] A. Morello and V. Mignone: **DVB-S2: The Second Generation Standard for Satellite Broad-band Services**
Procs IEEE, Vol. 94, No. 1, January 2006.
 - [5] M. Cominetti, A. Morello and M. Visintin: **Wide RF-band HDTV emission systems: Performance of advanced channel coding and modulation techniques**
EBU Technical Review, Spring 1992.
 - [6] C. Dosch (IRT): **Digital broadcasting of studio-quality HDTV by satellite in the 21 GHz frequency range and by coaxial cable networks**
EBU Technical Review, Summer 1993.
 - [7] ITU-R: Report BO. 2071, Annex 2.
 - [8] A. Dissanayake: **Ka-Band Propagation Modeling for Fixed Satellite Applications**
Online Journal on Satellite Communications, Issue. 2, 2002.
 - [9] Hisashi Sujikai, Yoichi Suzuki, Shoji Tanaka and Kazuyoshi Shogen: **Super Hi-Vision Transmission Experiment in the 21 GHz band**
NAB-2008.
 - [10] Shoji Tanaka, Kazuhiro Yamagata, Susumu Nakazawa, Naoto Kogou, Hisashi Sujikai and Kazuyoshi Shogen: **21 GHz-band Direct Broadcasting Satellite System**
AIAA, 2007.
 - [11] Kazuhiro Yamagata, Shoji Tanaka and Kazuyoshi Shogen: **Broadcasting Satellite System Using Onboard Phased Array Antenna in 21-GHz Band**
IVEC, 9.3, pp.209-210, 2007.
 - [12] ETSI TR 102 376: **Digital Video Broadcasting (DVB): User guidelines for the second generation system for Broadcasting, Interactive Services, News Gathering and other broadband satellite applications (DVB-S2).**
 - [13] ETSI EN 302 755: **Digital Video Broadcasting (DVB);Frame structure channel coding and modulation for a second generation digital terrestrial television broadcasting system (DVB-T2).**
-