

Pseudo channel BER – an objective quantity for assessing DAB coverage

R. Schramm (IRT)

In the case of analogue broadcasting, it is often regarded as adequate to measure just the received field strength in order to evaluate the coverage obtained by a transmitter. With digital broadcasting, however, it is absolutely essential to measure additionally the bit error rate in the received signal.

While the net BER in the decoded audio signal can be used to assess the coverage of a DAB service, it requires the transmission of a special test signal which uses up a complete sound channel in the DAB multiplex.

In this article, the Author proposes the use of a so-called “pseudo channel BER” as an objective quantity for assessing the coverage of a DAB service. This method does not require the use of a specially transmitted test signal; it is applied to ordinary DAB programme material.

1. Introduction

DAB is currently being tested successfully in pilot projects in a number of German states, and the introduction of a permanent service is imminent. An objective measurement method is needed for assessing the coverage area of every DAB service. Cyclic redundancy check (CRC) words embedded in the signal have been used with DAB in the past as a measure of the reception quality [1], [2]. However, they suffer from the disadvantage that CRC errors do not show up until the bit error rates (BERs) are already high enough to cause clearly audible interference. Consequently, these measurement quantities are mainly suitable at the edge of a DAB coverage area. It is necessary to use a different measurement quantity (or measuring method) in order to detect weaker interference inside the coverage area. A number of ideas and proposals have been put forward in the literature [3] and by various broadcasting study groups. However, the measurement quantities or methods proposed to date are difficult to put into practice for various reasons.

Original language: German
Manuscript received 19/9/97.

This article is also being published in German in the Winter issue of Rundfunktechnische Mitteilungen (RTM) – the quarterly review of the IRT.

The DAB logo has been registered by a member of the Eureka-147 DAB consortium.

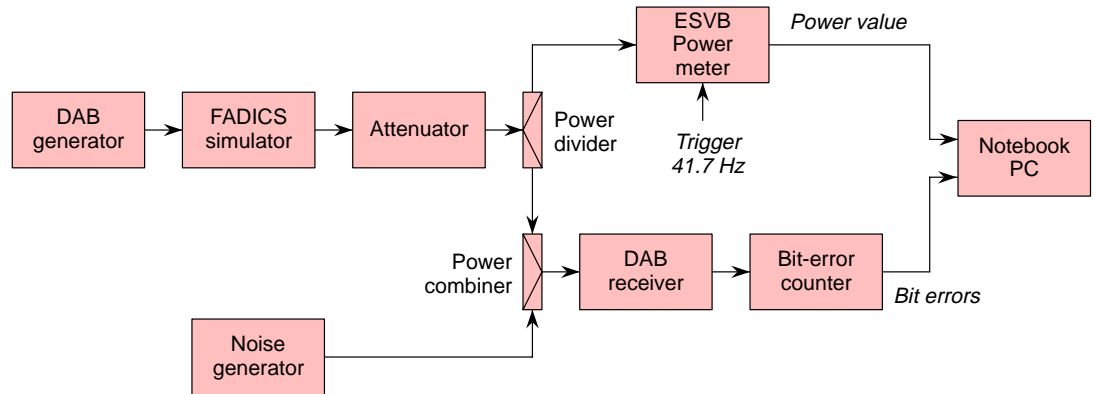

Figure 1
The test set-up for measuring the pseudo channel BER.

For analogue broadcasting it is often regarded as adequate to measure the received field strength in order to evaluate the coverage whereas, for digital broadcasting, it is absolutely essential to measure additionally the error rate in the received signal. One reason for this can be found in [3] which also contains a proposal to use the *net BER* (bit error rate in the decoded audio signal at the output of the Viterbi decoder) to assess the coverage.

Although measurement by using the net BER is very accurate, it has one great disadvantage: it requires the transmission of a special test signal which uses a complete sound channel, something which is not normally possible because all the channels are permanently used for programmes. A compromise solution must be found to enable coverage measurements to be made within the service area, even if the results are slightly less accurate.

It is proposed here that, in addition to the received field strength, a so-called *pseudo channel BER* (pcBER) is used as an objective quantity for assessing the DAB coverage.

2. Pseudo channel BER as an objective measurement quantity

The decoder chips used in DAB receivers make it possible to measure the pcBER without using a test signal: the bitstream at the output of the Viterbi decoder is re-encoded and compared with the corresponding buffered bitstream at the input to the Viterbi decoder. Any disparities between these two bitstreams – which indicates that there are transmission errors – are flagged and can be counted as bit errors.

The pcBER is calculated by dividing the number of bit errors per audio frame (24 ms) by the number of corresponding net bits, i.e.:

$$pcBER = \frac{\text{No. of bit errors per audio frame}}{\text{No. of corresponding net bits}}$$

The pcBER is equivalent to the *channel BER* when the reference bitstream at the output of the decoder is free of errors. However, this measurement method produces inaccurate results if there are uncorrected bit errors in the reference signal (not corrected by the Viterbi decoder).

Low measurement errors occur while measuring the pcBER over the range of bit error rates found within the service area of a transmitter, since this is a region where reception of the broadcast signal is generally good (net BER less than 10^{-4}). The corresponding channel BER is much higher, which means that errors in the reference signal have a relatively small influence on the measured value. The measurement error only becomes large at higher net BERs. This is not necessarily a disadvantage when carrying out coverage measurements. Around the threshold for good reception (net BER = 10^{-4}), the measurement is relatively accurate. As soon as the number of errors in an audio frame exceeds the threshold value, the measurement location is deemed to be *not covered*, regardless of the excess level. The exact BER in this case is irrelevant.

There is a further drawback to measuring the coverage by means of the channel BER. It is not possible, using the value for the mean channel BER alone, to predict how large the mean *net BER* at the output of the decoder – and what the *audible impairment* effects – will be. These two quantities are also influenced by the specific reception conditions, i.e.:

- the travelling speed;
- the nature of the terrain;
- the design of the DAB receiver.

Although the influence of the DAB receiver on both the audible impairment and the net BER is

only of secondary importance, different audible interference effects can occur for a given mean net BER. More important though is the influence of the other two parameters – travelling speed and terrain (channel) type – on the BER. If these parameters are constant and known along specific sections of the route, the net BER can be derived from the channel BER.

As far as possible, the travelling speed should be kept at a constant preset value during the coverage measurements and, at the same time, it must be measured, recorded and included in the analysis. If the speed of the vehicle is known but the nature of the terrain has not been recorded, it is possible to infer the terrain type from the size of the channel BER variations and, thus, calculate the corresponding mean net BER to a satisfactory degree of accuracy (see Section 4).

3. Estimating the error in measuring the pcBER

3.1. Measuring the mean pcBER

The statements made in Section 2 about measurement errors will be substantiated here. The pcBERs were measured with the aid of the measurement set-up illustrated in Fig. 1 using a FADICS channel simulator from Grundig in order to simulate the following [4]:

- a Gaussian channel (referred to as NOFADING);
- journeys made at four different travelling speeds in a typical urban area (TYPURB1 channel);
- journeys made at four different travelling speeds in a rural area (RURAL1 channel).

A DAB signal generated at the IRT was fed to the FADICS channel simulator. The output signal – at 225.648 MHz – was then split equally between a power meter (Rohde & Schwarz ESVB) and a Philips DAB 452 receiver. White noise was added to the DAB signal at the input to the receiver, at a level approximately 30 dB higher than that of the inherent noise in the system.

The ESVB power meter – activated by a 41.7 Hz trigger signal – performed a power measurement during each audio frame (24 ms) and the result was transferred to a notebook PC. At the same time, a bit error counter – connected downstream of the DAB receiver – passed on the number of bit errors per audio frame to the notebook PC. For every audio frame, the power measurement and the associated bit error count were recorded as a pair. The level of the DAB signal was varied in 1 or 2 dB steps over a carrier-to-noise ratio (C/N) range of 5 to 45 dB. At each setting of the DAB signal level, 500 audio-frame measurements were made (and hence the setting changed every 12 seconds).

The measurements were made on a DAB audio programme, delivered at 192 kbit/s with PL3 error protection.

Figure 2
Mean pcBER as a function of the mean C/N.

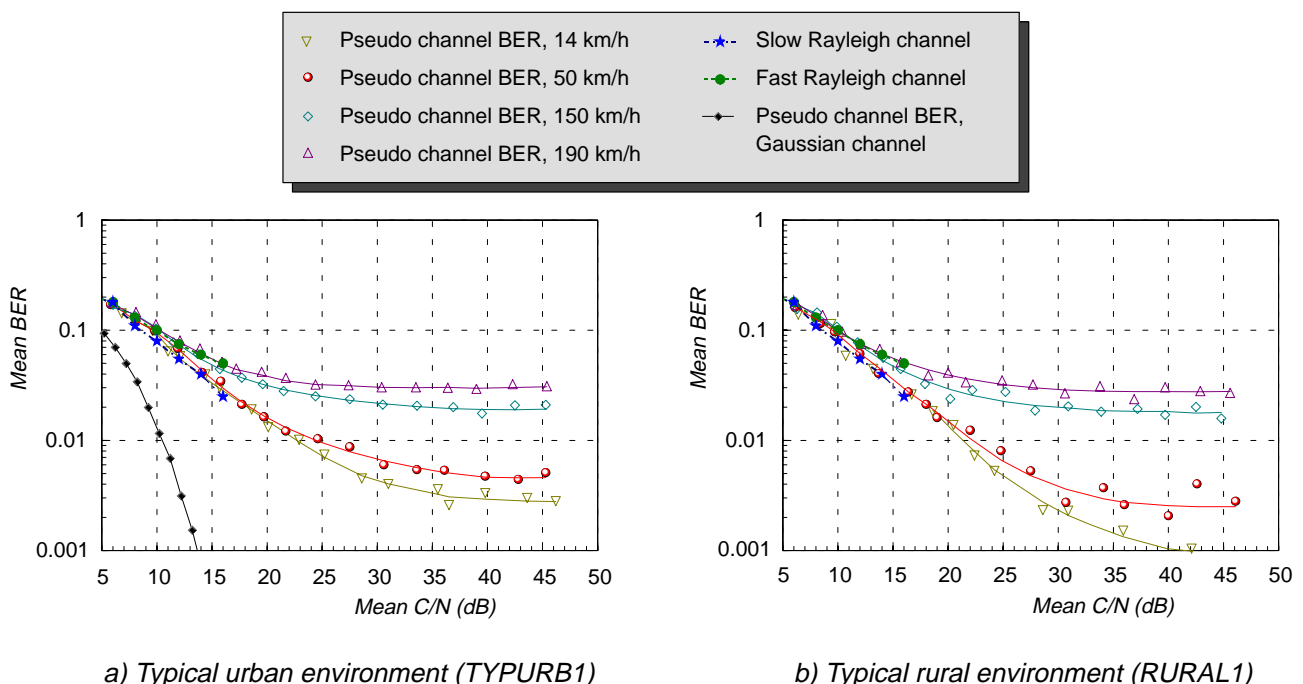

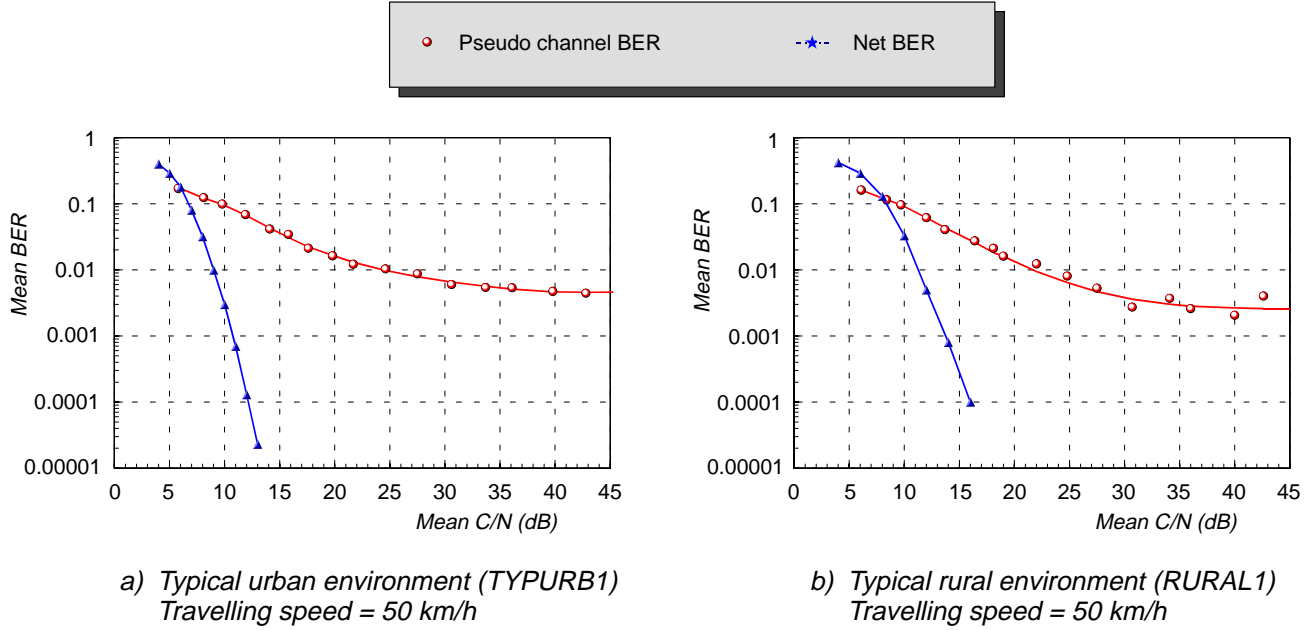

Figure 3
Mean BER at the input and output of the Viterbi decoder.

3.2. Comparison with the theoretical curves

In order to eliminate the switching process, only the last 350 of the 500 values measured during each level setting were analysed. The *mean power* and *mean pcBER* were then calculated. The results are illustrated in *Fig. 2*. The mean pcBER is shown as a function of the mean C/N, at four travelling speeds, and compared with corresponding theoretical curves for uncoded DQPSK signals in a slow and a fast Rayleigh channel, as described in [3, *Fig. 2* and *Fig. 3* where $E_S / N_0 = C/N$].

In both environments (TYPURB1 and RURAL1), the mean pcBER curves, measured at the lowest travelling speed ($v = 14$ km/h), match very well the theoretical curve for a slow Rayleigh channel. Similarly, the mean pcBERs measured at the highest travelling speed (190 km/h) match very well the theoretical curve for a fast Rayleigh channel. The maximum relative error in the C/N range from 6 to 10 dB is 20% and drops below 10% if the C/N exceeds 12 dB. Unfortunately the theoretical comparative values are only available for the C/N range from 6 to 16 dB. However, matching of the curves can only improve for larger C/N values since the net BER decreases much faster than the channel BER as the carrier-to-noise ratio increases.

The curves in *Fig. 2* confirm that the mean pcBER in the range slightly above and below the threshold value for good reception (an important range for coverage measurements) corresponds closely to the mean channel BER. The mean pcBER can therefore be used very well, instead of the mean

channel BER, as an objective quantity when carrying out coverage measurements.

The instantaneous pcBER is subject to greater variations, due in part to errors occurring during the re-encoding process but primarily due to the inherent nature of the system. The extent of these variations is analysed in the following section.

3.3. Maximum possible error in measuring the pcBER

Bit errors occurring in the bitstream at the output of the Viterbi decoder cause errors in the re-encoded reference signal as already mentioned. The convolutional encoder responsible for re-encoding has a constraint length of six. A bit error in the input datastream (net bits) to this encoder influences the output datastream for a maximum duration of seven bit cycles, the time needed for it to run through the six-digit shift register. (The bit error at the register input already has an influence on the output value.) A net bit error in the reference signal can therefore cause a maximum of seven false bit errors (although there are usually fewer) and thereby can alter the pcBER. The greater the ratio between the BER at the input and the corresponding value at the output of the Viterbi decoder, the smaller the relative measurement error.

As an example of how to estimate the maximum possible error when measuring the pcBER, the curves in *Fig. 2* for the mean pcBER at a travelling speed of 50 km/h – in both the TYPURB1 and RURAL1 channels – are displayed in *Fig. 3* together with the mean net BER curves measured under identical conditions at the IRT [5].

The C/N values corresponding to the threshold value of 10^{-4} net BER – at a travelling speed of 50 km/h – are 12 dB for the TYPURB1 channel and 16 dB for the RURAL1 channel. It can be seen from the diagrams that the mean pcBER corresponding to the threshold value is 6.5×10^{-2} for a TYPURB1 channel and 3×10^{-2} for the RURAL1 channel. There is one net bit error for every 650 pseudo channel bit errors in the first case, and for every 300 in the second case.

The maximum measurement error that is possible when measuring the mean pcBER is shown in Fig. 4. This is calculated by dividing the seven-fold net BER (a maximum of seven channel bit errors are detected in the case of a net bit error) by the BER at the input to the decoder. The measurement error at the threshold value of 10^{-4} net BER is $\pm 1.1\%$ for the TYPURB1 channel and $\pm 2.3\%$ for the RURAL1 channel. At net BERs of 10^{-3} (C/N = 11 dB and 13.5 dB) the maximum measurement error is $\pm 8\%$ and $\pm 20\%$ respectively.

In conclusion, the maximum error when measuring the mean pcBER – in the range around the threshold value that is relevant for coverage measurements – is generally less than $\pm 2.3\%$, a perfectly acceptable value. As mentioned before, the measurement error below the threshold value is smaller, while above the threshold value it can be ignored because it is included under the definition “faulty reception”.

The distinction between pcBER and channel BER is omitted from now on.

3.4. Channel BER variations

The variation in the instantaneous channel BER caused by the measuring method amounts to a maximum of only 2.3% whereas variations inher-

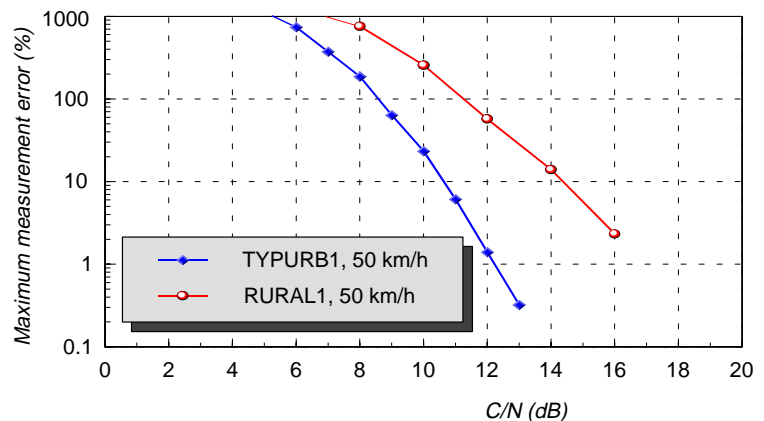

Figure 4
Maximum measurement error when measuring the mean pcBER at $v = 50$ km/h.

ent in the system are much greater. At constant mean signal power, the power received in the Rayleigh channel at a particular moment varies and the bit error rate changes accordingly. The extent of the change depends on two parameters, the *channel type* (urban area, rural area, etc.) and the *travelling speed*.

The variations of 350 bit error values at the same mean received power have been analysed statistically using the raw data for the measurements of the mean pcBERs that are shown in Fig. 2. The bit error values for a frequency of 16% and 84%, i.e. a variation of \pm one standard deviation from the mean value, were derived from the statistical distributions of the measured values. These bit error values, divided by the number of net bits per audio frame, are represented in Fig. 5 as boundaries on a vertical line at the corresponding mean C/N for a travelling speed of 50 km/h (from Fig. 2).

The bit errors in the urban area (TYPURB1 channel) are fairly evenly distributed. The variation in the error rate is not particularly large (Fig. 5a). In the rural area (RURAL1 channel) there are large variations in the level of the received power which

Figure 5
Variation of the channel BER in the range of the mean value \pm standard deviation.

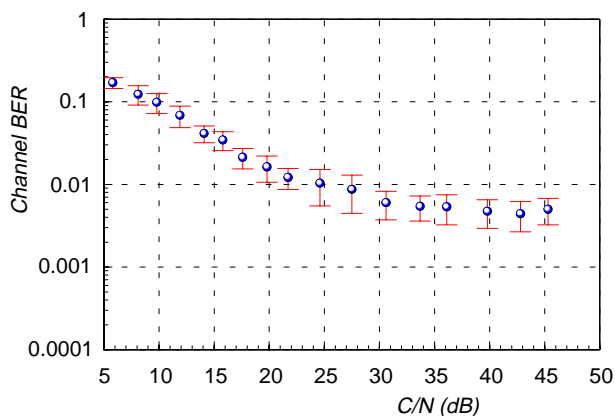

a) TYPURB1 channel, 50 km/h

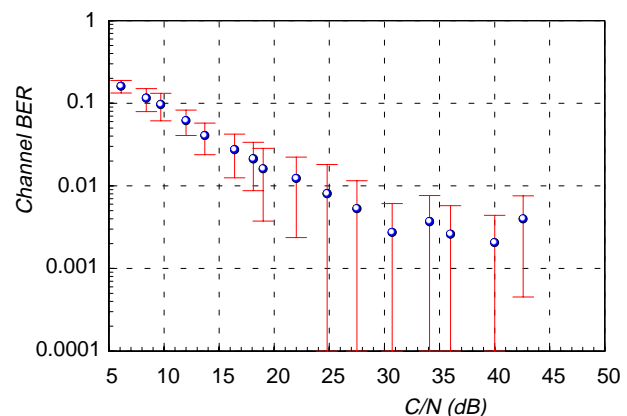

b) RURAL1 channel, 50 km/h

cause more burst errors. This results in large variations in the error rate (*Fig. 5b*).

The variation in the channel BER at the same mean value differs according to the channel type and the travelling speed. The type of channel can be derived from the size of the mean value and the variation in the channel BER at a known constant travelling speed. Once the channel type is also known, it is possible to determine from a diagram, such as the one in *Fig. 3a*, the corresponding mean channel BER which is equivalent to a mean net BER of 10^{-4} .

The variation range of the measured values for the channel BER provides information about the error range of a single measurement. It influences the accuracy with which the boundary between a covered and a non-covered area can be found. Fortunately, the variation at high BERs, close to the threshold value and above, is smaller than at low values.

Some actual values can be taken from *Fig. 5*. At the threshold value (net BER = 10^{-4}), which is at C/N = 12 dB in the TYPURB1 channel, the vertical boundaries are at $\pm 32\%$ from the mean value. These limit values correspond to a shift of the C/N value in the range -1, +2 dB on the curve of the mean channel BER. In the RURAL1 channel, the threshold value is at C/N = 16 dB, and the vertical boundaries of the channel BER variation, at either side of the mean value, are $\pm 50\%$ of it. This corresponds to a shift in the C/N value in the range -2, +6 dB. Unacceptably large errors can therefore be made with single measurements. One way to reduce the errors is to average the measured values (sliding mean value) as proposed in [3]. However, averaging of the measured values must not be taken too far since single momentary peak val-

ues of the channel BER that exceed specified limits can result in audible errors, even if the mean value is below the threshold.

The large variations in the measured values are not a specific weakness of the measurement method proposed here. The net bit errors fluctuate by a similar amount to that given in [3, Figs. 4a and 4b]. In [3], it is also suggested that the measured values should be averaged, in order to improve the measurement accuracy.

Fig. 6 shows the bit errors in 350 audio frames, measured in a TYPURB1 channel and a RURAL1 channel at an input mean power level that is set to the threshold value for interference-free reception, at a travelling speed of 50 km/h.

Comparing *Fig. 6a* and *Fig. 6b*, it is again apparent that the relative variation in the individual values of the channel BER, around the threshold value for good reception, is smaller in the TYPURB1 channel (ratio = 1:4) than in the RURAL1 channel (ratio = 1:30). However, in the first case, the absolute values are noticeably larger on average.

There are fewer burst errors and therefore fewer variations of the error rate after de-interleaving in the TYPURB1 channel, and the Viterbi decoder can effectively correct the errors. In the RURAL1 channel on the other hand, there are a large number of burst errors which result in large variations in the error rate, even after de-interleaving so, consequently, the Viterbi decoder can correct fewer errors. In order to achieve the same mean net BER of 10^{-4} , the mean signal power in the RURAL1 channel has to be 4 dB higher than in the TYPURB1 channel.

A channel with small variations of the BER (TYPURB1) and one with very large variations

Figure 6
Channel bit errors
per audio frame at
constant mean
power.

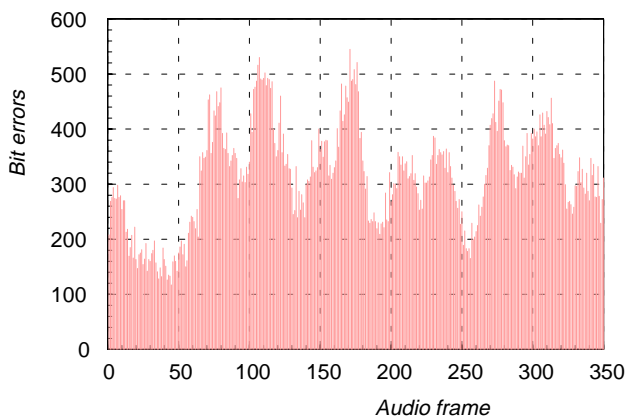

a) TYPURB1 channel, 50 km/h
(net BER = 10^{-4} , C/N = 12 dB)

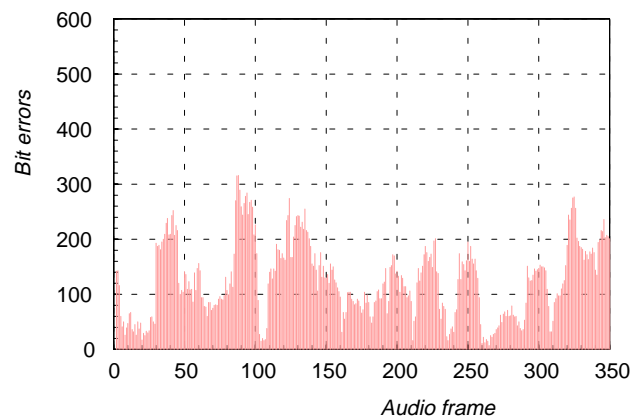

b) RURAL1 channel, 50 km/h
(net BER = 10^{-4} , C/N = 16 dB)

(RURAL1) were deliberately selected for the measurements. The variations in the error rates in other channels, e.g. BADURB1, HILLY1, SFN1 [4] appear predominantly in the centre of the variation range.

4. Outline of a measurement method

A car with measurement equipment drives along selected roads in the coverage area, keeping as far as possible to a constant speed, e.g. 50 km/h in towns. The DAB signal is routed from a horizontal isotropic receiving antenna, mounted on the roof, to a measurement receiver. Between the receiving antenna and the measurement receiver is a directional coupler with low insertion loss which extracts a small portion of the power and feeds it to a power meter.

A DAB measurement receiver counts the channel bit errors in each audio frame and forwards them to a computer for analysis. The power meter, which measures the received power on a wide-band basis, is triggered locally, i.e. a device connected to the wheels triggers a power measurement in the vehicle when it drives along a particular stretch of road. The measured power values are also forwarded to the computer.

The computer calculates the mean channel BER and the standard deviation of the variations over stretches of the route. It verifies whether the travelling speed was constant and calculates its value. The distance driven is proportional to the number of power measurements made, and the time taken is proportional to the number of audio frames measured. The computer uses the size of the variation and the average value of the channel BER as a basis for estimating the channel type. It then ascertains the threshold value of the channel BER for good reception, by correlating the channel and net BERs. If the mean channel BER along a par-

ticular stretch of the route is below the threshold value and the received power exceeds a required minimum level, this indicates that this stretch of the route is covered for DAB.

The coverage percentage of a region is calculated from the coverage of the individual stretches.

Initial coverage measurements should also be analysed to establish whether peak values of the channel BER are useful for evaluating the coverage.

5. Conclusions

The channel BER appears to be well suited for the purposes of taking DAB coverage measurements. It has the great advantage that it can be measured while a programme is being broadcast, without the need to transmit special measurement signals. It can be measured with sufficient accuracy for quantities around and below the threshold value for interference-free reception.

The channel BER is closely correlated to the net BER. The correlation is influenced by two parameters – the *travelling speed* and the *channel type* (type of surroundings). This means that if the travelling speed and the channel type are known, the mean net BER can be derived from the mean channel BER to a satisfactory degree of accuracy. The speed should be kept constant at a predefined value during the measurements. If the nature of the surroundings is not recorded, it can be determined from (i) the mean value of the channel BER and (ii) the size of the variations in its individual values.

The equipment set-up for taking coverage measurements is uncomplicated. Fast measurements in moving vehicles can be made with the devices readily available on the market today, with a measuring rate of more than 500 measurements per second. Online analysis of the results is also possible.

Mr Raul Schramm, born in 1948, studied Electronic Engineering at the Polytechnic Institute of Bucharest, Romania. After completing his studies in 1971, he joined the Polytechnic Institute as an assistant in the Electronics faculty. There, he worked in the field of antennas, microwave and radar techniques, and later became a lecturer at the same faculty, teaching microwave theory and techniques.

In 1983, Mr Schramm joined the Institut für Rundfunktechnik (IRT) as a research engineer. Here he worked in the Antennas and Propagation Department, carrying out propagation studies of single-carrier and broadband signals, analyzing signal-fading statistics and developing the software and hardware for automated measurements.

With the emergence of digital broadcasting systems, Raul Schramm became involved in the development of test methods and systems for digital radio and television. He was involved in the European JESSI-DAB and JESSI-DDB digital radio projects where he was in charge of the field tests workpackage. He now works in the digital terrestrial television project, VALIDATE DVB-T.



A precise definition of the coverage has still to be specified. It should define a standard measurement method.

Certain factors that may influence the measurement result should be borne in mind:

- The field strength and BERs should be measured at points distributed as evenly as possible over the region under investigation. This calls for careful selection of the measurement routes. The individual measurements made while travelling over these routes must be triggered locally so that stretches that are driven slowly are not overvalued.
- The travelling speed should be uniform and matched to the surroundings, e.g. 50 km/h in towns and 80 km/h in rural areas. The error rates at other speeds can then be estimated with the aid of theoretical investigations and laboratory measurements.
- The reception set-up (antenna, vehicle, etc.) and the DAB receiver should be specified precisely, since they influence the results.

Acknowledgements

The author would like to thank Mr Günter Schneeberger (IRT) for his valuable suggestions and for his critical review of this article.

Bibliography

- [1] Schramm, R. : **Verhältnis zwischen empfangener Leistung und dem Fehlverhalten von DAB-Empfangssystemen; Einfluß von Impulsstörungen** (Relationship between received power and malfunctioning of DAB reception systems; influence of impulse noise)
Tech Report IRT No. B 141/94, April 1994.
- [2] Lau, A., Pausch, M.; Wüschner, W.: **Erste Ergebnisse aus den Untersuchungen mit dem DAB-Gleichwellennetz in Bayern** (Initial results from studies made with the DAB single frequency network in Bavaria)
Technical report of DAB Plattform e.V., Munich 1993.
- [3] Frieling, G., Lutter, F., Schulze, H.: **Bitfehlermessungen zur Beurteilung der DAB-Rundfunkversorgung** (Bit error measurements for assessing DAB broadcasting coverage)
Rundfunktech. Mitt. 40, 1996, pp 123 to 133.
- [4] COST 207 Management Committee: **Digital land mobile radio communications**
Commission of the European Communities; information, technologies and sciences.
Final report, Brussels, 1989.
- [5] Weck, C., Caldenhoven, F.: **BER and CRC measurements using 3rd Generation COFDM**
Internal IRT Report, Munich, December 1993.

Writing for the EBU Technical Review

The Review welcomes articles from broadcasting organizations, broadcast research institutes and the broadcast manufacturing industry.

Our readers are interested in theoretical studies, explanations of new broadcasting technologies and techniques, descriptions of major broadcasting development projects, reports on the broadcast coverage of large-scale events, etc.

The **EBU Technical Review** is distributed to the engineering divisions of all the EBU Active and Associate member organizations throughout Europe and the rest of the world. It also has wide circulation among broadcast equipment manufacturers, universities and other specialist institutions.

For an Author's Information Pack, please contact:

The Editor
EBU Technical Review
Ancienne Route 17A
CH-1218 Grand Saconnex (GE)
Switzerland

Fax: +41 22 717 22 00
E-mail: techreview@ebu.ch