



# Dynamic Range Control (DRC) and Music/Speech Control (MSC)

## Programme-associated data services for DAB

W. Hoeg (DBP-Telekom – FTZ)

N. Gilchrist (BBC)

H. Twietmeyer (IRT)

H. Jünger (Jünger Audio)

### 1. Introduction

The Eureka 147 Digital Audio Broadcasting (DAB) system [1, 2, 3] provides not only a very high audio quality for the listener in general, but also includes provision for many additional data services. Most of these data services are independent of the audio programme, but some of them are closely related to the audio signal. The latter form the so-called Programme Associated Data (PAD), which includes the Dynamic Range Control (DRC) System and the Music/Speech loudness Control (MSC) system. Some other special features will be provided by the DAB system to tailor the reproduced audio signal to the individual requirements of each listener in his individual reception environment, and so improve the acceptability of future audio reception in general.

In order to offer an overview of data services for DAB, a general review is given. This is followed by the basic requirements, the strategy and the principles of DRC for DAB, based on the requirements of Eureka 147, the International Telecommunication Union (ITU) [2] and the European Telecommunication Standards Institution [3], together with systems for the real-time implementation of DRC for DAB.

Original language: English  
Manuscript received 2/9/94.

The DAB logo has been registered by a member of the Eureka 147 – DAB consortium.

*There will always be the need for broadcasters to apply dynamic range compression to some types of programme material, either because of the limitations of the broadcasting medium or because of listeners' requirements.*

*The Eureka 147 DAB digital audio broadcasting system enables broadcasters to transmit programmes with a relatively wide dynamic range, accompanied by a dynamic range control (DRC) signal which the listener may use to effect unobtrusive compression of the programme dynamics, if required. A music/speech control (MSC) signal, which is also transmitted, will enable the listener to balance the loudness of different types of programme according to taste.*

*The techniques used for the optional compression of programme dynamics in DAB may also be used to control the dynamic range of programmes unobtrusively for conventional VHF/FM broadcasting, but without control data being transmitted.*

## 2. Data facilities in DAB

### 2.1. Architecture of the DAB ensemble

Although the DAB system is designed primarily for the broadcasting of audio programmes, its architecture is intended to offer the greatest flexibility for non-audio applications, so that the best use can be made of the limited resources of the RF spectrum and the overall data capacity of the DAB signal. As an international standard the system must be readily adaptable to specific national or local needs. It must also be adaptable to future applications, such as multimedia services.

The ensemble of audio programmes and data services carried by a DAB signal can be described according to a hierarchy of three levels:

- The *service level* telling the listener which services are available.
- The *service component level* informing the listener of the components which comprise the service.
- The *channel level*. The DAB capacity is partitioned in a set of sub-channels. Each audio service component resides in a sub-channel of its own. A data service component can reside in a sub-channel of its own as a continuous stream in multiples of 8 kbit/s, segmented in 24 ms frames (stream mode), in the so-called Fast Information Channel (FIC) at low rates, of 100 bit/s or less, or it can share a sub-channel with other data service components in a packet multiplex (packet mode).

Included in the FIC is the Multiplex Configuration Information (MCI). This comprises all the information needed to get fast access to every service and its components. The MCI describes in detail how each service component can be accessed (i.e. in which sub-channel it is to be found), the gross and net bit rate, and any other details (e.g. the error protection scheme).

### 2.2. Categories of data in DAB

The DAB ensemble can contain four different categories of data:

- *General data services*, independent from other data or audio services.

The DAB system offers a flexible transport mechanism (with options for conditional access), that can be used equally well for non-audio data services. The robustness of the DAB system and its RF char-

acteristics guarantee that DAB data services will be well suited for reception in cars and portable devices. A stationary DAB receiver built into a PC could serve as a data service terminal or be used as a multimedia receiver.

Data services from a small number of service providers may be distributed as one single DAB ensemble to all private end users, e.g. the population of a town or of a whole country. Typical applications could be the distribution of computer programmes, computer games, traffic guidance, price lists, electronic newspapers and weather reports.

- *Data as a service component of an audio programme*

Nowadays radio and television programmes offer data facilities that are linked (by technical mechanisms) to the selected programme. Traffic message information (TMC) and teletext are examples of these. In the DAB system, different data service components may be linked either to an audio service or to another data service. By using this option the programme provider may increase the attraction of his programme by offering additional facilities to his listeners. Applications may include textual information on the programme schedule, detailed information about the topic addressed by the audio, the manuscript of a lecture, maps, still pictures referring to a news report, and travel information. Several co-operating programme providers may share the same service component. All listeners to the different co-operating programmes have access to all of the information.

- *Basic Service Information (SI)*

Like the Radio Data System (RDS) in FM broadcasting, the DAB system offers basic service information (carried in the FIC in machine-readable form) to assist the listener and his receiver to select a service. It comprises programme service labels displayed by the receiver, identification of the programme language and programme type, cross references to other programmes, transmitter identification for navigation purposes or for geographical selection of information, and automatic control for presenting special announcements (e.g. news, traffic information). The extent of these SI features goes far beyond the features of RDS and is capable of meeting needs which will evolve in the future.

- *Programme Associated Data (PAD)*

Data travelling in the PAD channel is intimately related to the audio programme. It is assembled together with the coded audio in the same DAB frame, so the time relation established at the source is maintained throughout the complete DAB trans-

mission chain. So audio and PAD cannot be subject to different transmission delays. Therefore PAD is well suited to time critical data such as DRC data.

Because of the strong relation between audio and PAD, the programme associated data can be accessed by the receiver only in conjunction with the audio. The PAD channel consists of a fixed part (F-PAD, 2 Bytes per 24 ms frame, i.e. 0.66 kbit/s), and optionally of an extended part (X-PAD, comprising 0, 4, or more than 4 bytes per 24 ms, depending upon the “free” data capacity in the audio frame). The first DAB receivers will be able to cope with up to 16 kbit/s of PAD.

The X-PAD may include textual information about the audio programme (title, schedule) and the actual programme item (title, composer, opus, artist etc.). Some listeners will be interested in having lyrics, song or opera texts simultaneously translated from the original language to the language commonly used in the coverage area of the DAB signal.

The F-PAD can convey codes to identify an item of music (Universal Product Code, International Standard Recording Code). However, the main purpose for the F-PAD is to carry time-critical programme-related data. Transport mechanisms are defined for controlling additional devices (e.g. memory read out for still pictures), Music/Speech Control (MSC) and Dynamic Range Control (DRC). In each audio frame, 6 bits of F-PAD (i.e. about 250 bit/s) can be assigned for the transmission of DRC data.

Fig. 1 shows the structure of the PAD field within the DAB audio frame. More detailed information

on the total DAB multiplex and system support features can be found in [1] and [3].

### 3. Dynamic range control (DRC)

#### 3.1. General

The dynamic range of an audio programme signal (sometimes termed the programme dynamic) is the range between the highest and the lowest useful programme signal level. The problems associated with programmes having a wide dynamic range, and with achieving a satisfactory loudness balance between different parts of the radio programme (such as speech or music) are well known from experience with VHF/FM [4, 5]. In many cases the source programme dynamic range may be much larger than the available dynamic range of the transmission channel; it may also be much larger than the usable dynamic range in noisy environments such as cars (the so-called reproduction dynamic). The reduction required in the dynamic range of the programme may be 10 to 30 dB (or more). Fig. 2 shows the dramatic differences in the reproduction dynamics to be expected (based on figures given in [6]). In addition, there may be very different requirements in the loudness balance between music and speech programmes, depending on the interests of the listener and the conditions for reproduction [5, 7]. During the last 30 years operational practices have evolved to try and solve these problems. These have included:

- reducing the dynamic range of sound recordings and live transmissions by manual fader control to within a maximum range of 40 dB in order to match this range to the characteristics of the available transmission channel (AM, FM), as well as to that of listening conditions in a typical living room [4, 8, 9];

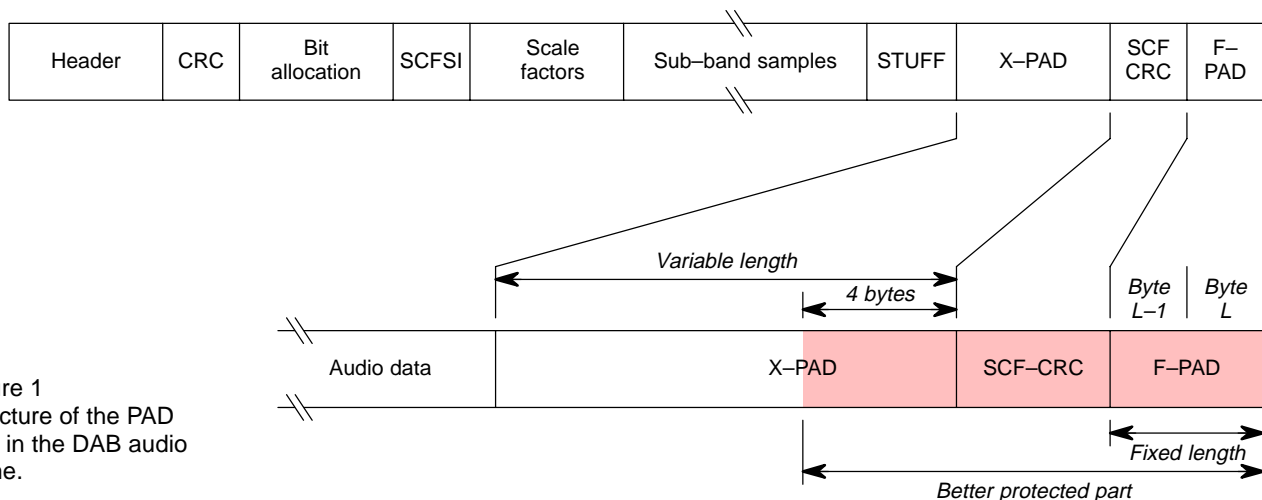

Figure 1 Structure of the PAD field in the DAB audio frame.

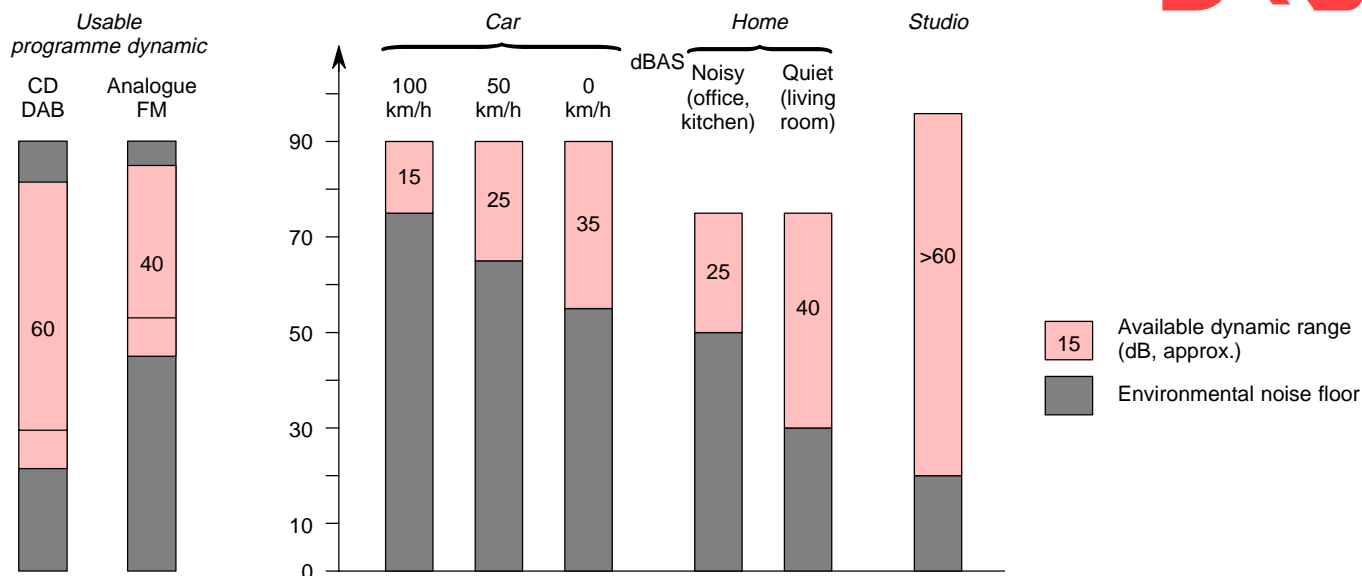

Figure 2  
Reproduced dynamic range.

- controlling different programme types (speech, symphonic music, chamber music etc.) to different maximum levels in order to make the perceived loudness conform to a particular requirement [7, 8, 10, 11].

The dynamic range commonly used by the broadcasters (ca. 40 dB) may well be too large for poor listening conditions (e.g. in a moving car) and the number of recordings with a much more extended dynamic range (taken from CD or other digital recording media) is increasing dramatically. So the need for dynamic range control is increasing. Furthermore, the balancing of different types of programmes by broadcasters may not be ideal for all listeners. This means that these problems can only be solved at the receiver, taking into account the listening conditions and the requirements of the listener. For this to be feasible, additional information must be provided by the broadcaster concerning the current type of programme and the gain adjustments which may be needed to reduce the dynamic range.

### 3.2. State of the art

In addition to the methods used by broadcasters to solve dynamic range problems by operational practices, proposals for using a type of compander system (compression at the studio side with expansion at the receiving side) have been made [4], but there has been no practical implementation of this.

A method for “Variable Dynamic Range” has been proposed, using a dynamic control signal derived either from a fader unit operated by a sound engineer, or from a dynamic range processing unit [12].

The control signal, transmitted in parallel with the audio programme signal, may be used at the receiving side in order to compress or to expand the dynamic range of the reproduced audio signal. The intention is to effect a very smooth change of the gain, similar to careful control with a manual fader, and the facility for setting the balance in loudness between speech and music programmes is included. However, the hardware realisation [13] needs a relatively long look-ahead-time (5–10 seconds), and a relatively high data rate to transmit the dynamic control signal.

Solutions fulfilling the Eureka 147 requirements for DRC data for DAB have been proposed by the BBC [14] and German Telekom [15]. Both systems need a significant look-ahead time. This is typically from 30 ms up to 3 seconds for the BBC system, and about 24 ms for the German Telekom system. More details of these systems are given in Sections 4 and 5 below.

Self-contained compressors, for use in receivers and operating without the need for transmitted control data, have been proposed by several authors [16, 17]. One of these, developed by the IRT [17], is based on scale factor weighting in the MPEG1–Layer 2 source decoder (the so-called MUSICAM–DRC system).

Table 1 gives an overview of possible dynamic range control system concepts. The existence of a practical system is indicated in the first column. The table shows, by the number of proposals, that there is significant interest in having dynamic range control systems in broadcasting.

System	Broadcast studio	Transmission	Receiver	Benefits	Disadvantages
1 FTZ/ Jünger [15]	Signal analysis with short look-ahead time DRC data generation	Transmission of DRC data simultaneously with audio data (according to ETS)	Decoding of DRC data Matching of audio signal level by means of re-generated DRC signal	Simple receiver function Improvable at the studio without changes in receiver Pre-compression possible, if required	Not usable for external sources at receiving end
2 BBC [14]	Signal analysis with optional long or short look-ahead time DRC data generation	Transmission of DRC data simultaneously with audio data (according to ETS)	Decoding of DRC data Matching of audio signal level by means of re-generated DRC signal	Simple receiver function Improvable at the studio without changes in receiver Pre-compression possible, if required Compatible with system 1	Not usable for external sources at receiving end Long look-ahead time may give problems with live transmissions
3 FTZ/ Jünger [15]	Signal analysis with short look-ahead time Pre-compression	No transmission of control data	Real-time self-controlled signal compression or expansion	Compatible with existing transmission systems such as VHF/FM	Practicable only with digitally-based receiver concepts
4 IRT [17]	No processing in the studio	No transmission of control data	Real-time self-controlled compression e.g. based on scale factor weighting (IRT, [17]) or by linear signal processing	Fairly low decoder complexity Usable also for external sources No need for standardization	System improvements will offer no benefits for existing receivers

Table 1  
Overview of possible DRC system concepts.

### ■ 3.3. Basic requirements

#### ■ 3.3.1. System requirements

In general, there are certain requirements which a DRC system must fulfil in order to guarantee a high audio quality:

- *Universality*: The system should be suitable for all kinds of future broadcast programme (radio or television).
- *Improvability*: It should be possible to improve or to change the characteristics at the transmitting side without changes needed in receivers.
- *Flexibility*: The listener should have the option of using DRC or not, with control over the degree of compression.
- *Reversibility*: A requirement for a system of pre-compression, for use with VHF/FM broadcasting, is that it should be possible at the receiver to restore the original dynamic range of the source programme (i.e. remove completely any changes in the dynamic range made at the transmitting end).
- *Compatibility*: If the programme is compressed by the broadcaster, it must be usable without any further processing at the receiver.

- *Low complexity*: The measures needed at the receiver for use of the system should cause a minimum of additional cost.
- *Delay*: Any delay in the signal path introduced by dynamic range control should be minimised. However, most processes introduce some delay, and as far as possible this should occur in the broadcasters' equipment, and not in the receiver.

#### ■ 3.3.2. Requirements for dynamic processors

In general, the intention is to compress the overall reproduced dynamic range for the listener whilst preserving the impact of a dramatic change in the programme dynamics, as well as the detailed dynamic structure within the music. If a signal with a reduced dynamic range is broadcast, with re-expansion at the receiver, the output signal should be virtually indistinguishable from the uncompressed source signal (this is only relevant to VHF/FM, see reversibility).

There are a number of characteristics defining the operation of a compressor or expander. The principal characteristics are described below.

The (static) operational gain characteristic (sometimes termed the gain law) indicates the output sig-

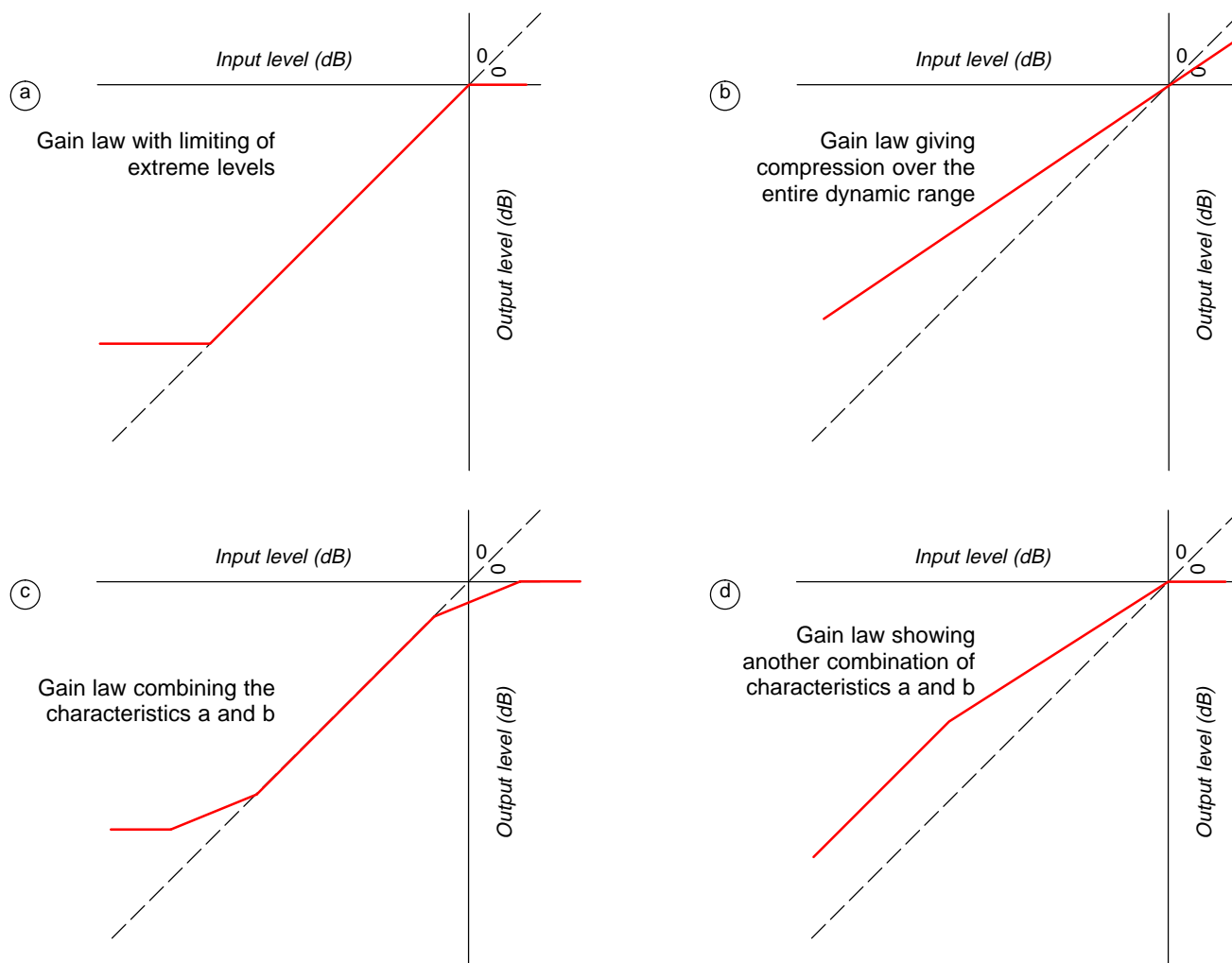

0 dB<sub>rel</sub> : relative to Permitted Maximum Signal level (ITU-R).

nal level as a function of the input signal level. Generally, this indicates that quiet signals are made louder, and loud signals quieter. Some examples of possible gain laws are shown in Fig. 3. The law shown in Fig. 3a would provide limiting at both extremes of the dynamic range; the law in Fig. 3b would compress all dynamics; that in Fig. 3c combines both of the previous laws. Fig. 3d shows another gain law derived from Fig. 3b, with no compression for extremely low levels.

For the simple characteristics such as those shown in Figs. 3b and 3d, it is possible to define a ratio of the input and output dynamic ranges, which applies over whole characteristic, or over any part of the characteristic:

$$\text{Ratio } r = \Delta L_{\text{in}} / \Delta L_{\text{out}}$$

where:  $\Delta L_{\text{in}}$  is the input dynamic range  
 $\Delta L_{\text{out}}$  is the output dynamic range

A static characteristic cannot fully describe the dynamic working of a compressor. It shows principally the gain values which are reached in a quasi-stationary state of the system. The real compression effect will be influenced by the dynamic parameters of the system, such as the attack time and the release time.

The attack time mainly influences the reaction time of the system to signal peaks, in order to reduce the gain in time to avoid reproducing excessively loud sounds, or causing over-modulation.

The release time determines the rate at which the gain can increase following loud programme material. A long release time gives gentle control of the programme level; a short release time enables the processing to follow the dynamics of the source programme more closely, compressing to greater effect but at the risk of introducing obtrusive effects such as “gain ducking” (or “pumping”) and non-linear distortion.

Figure 3  
Principal operational characteristics for DRC systems.

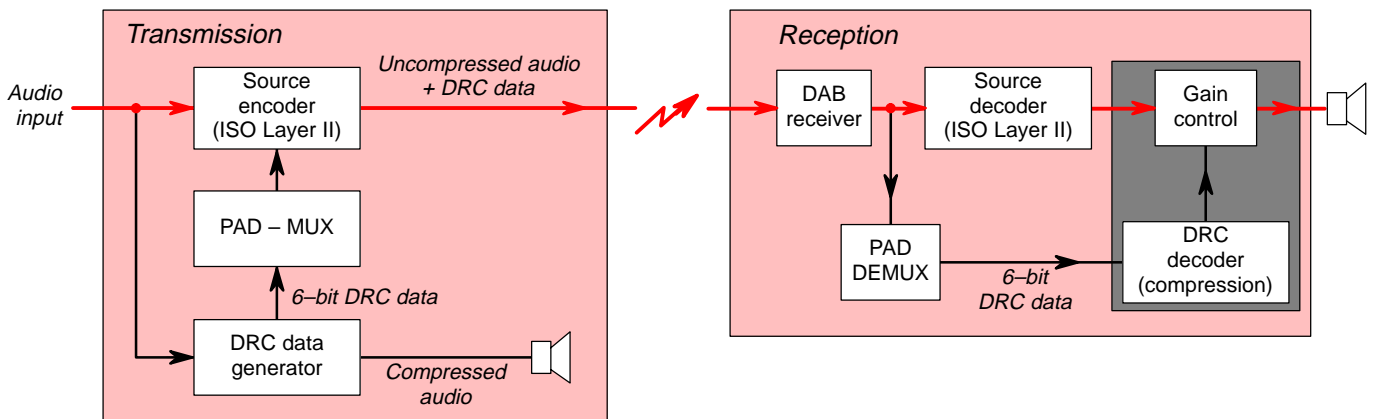

Figure 4  
Block schematic diagram of a DRC system for DAB.

In practice, different time constants may be used, depending upon the content and history of the audio signal (analysed during an appropriate look-ahead time) in combination with a defined static characteristic.

#### 4. DRC systems for DAB (with transmitted control data)

##### 4.1. Requirements of the DAB specification.

The requirement is to provide the potential for adapting the dynamic range of the broadcast programme to the individual needs of each listener. This can be realised by means of a Dynamic Range Control (DRC) system with transmitted control data, incorporated in the DAB signal [2, 3]. Fig. 4 shows a simplified block schematic diagram of a DRC system for DAB.

At the broadcaster's premises a DRC signal is generated, which describes the audio gain to be applied in the receiver, as a succession of values. This DRC signal is transmitted in a coded form ("DRC data") together with the audio signal. It is a requirement of the DAB specification [13] that the audio

signal is transmitted with its original programme dynamic, without any pre-compression.

The audio signal is bit-rate reduced by an ISO Layer 2 encoder. The DRC data is incorporated in the ISO Layer 2 bit-stream as programme associated data (PAD). Within the PAD, the data is formatted as shown in Fig. 1. A complete specification of the DAB data format, including the DRC data, is contained in the draft European Telecommunication Standard [3].

In the receiver, the regenerated DRC signal may be used to control the audio gain in order to match the dynamic range of the received audio programme to the requirements of the listener, or to improve audibility in difficult conditions.

##### 4.2. The Telekom DRC system

Telekom FTZ and Jünger Audio Inc. have jointly developed a Dynamic Range Control (DRC) system for DAB, conforming to the main requirements of the Eureka 147 DAB specification [3].

Fig. 5 shows a simplified block schematic diagram of the DRC generator. The audio source programme is analysed and DRC data is generated. Depending on the processing time (including a

Figure 5  
Block schematic diagram of the Telekom DRC signal generator.

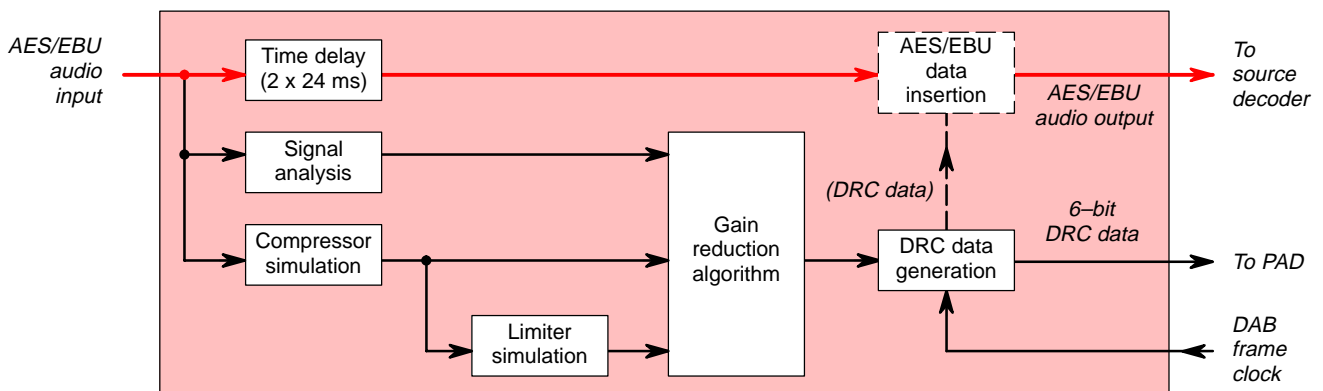

look-ahead time which is needed for an appropriate signal analysis), some delay must be introduced into the signal path. The Telekom system needs a delay equivalent to two 24ms-frames.

The DRC signal is generated by a characteristic which is linear over most of the dynamic range, with an appropriate compression ratio  $r$ . This is shown in Fig. 6. An overall range of gain variation of about 15dB is linearly coded in a 6-bit digital word, for each 24ms frame of the broadcast audio signal.

The intention is to provide long-term compression of the dynamic range whilst preserving the impact of dramatic changes in the programme dynamics. Therefore the generating algorithms use a specific set of time characteristics controlled by the audio programme, as mentioned above; these are not the subject of any specification. Optionally, it could be adjusted by a pre-set function to different types of programme.

The DAB audio programme signal is transmitted without any dynamic compression applied after the production/post-production stage. During the production of some types of programmes, compression may be applied for “artistic” reasons. Programme signals compressed at this stage are treated in the same way as uncompressed signals by the DRC system. The DRC data is sent out simultaneously with the audio signal to the receiver, and may be used optionally for controlling a (further) compression process in the receiver if the listener so wishes.

### 4.3. The BBC DRC system

Recognising that a suitably-trained operator (a studio manager in radio, or a sound supervisor in television) can produce very good results when controlling the audio programme level, the BBC has developed a control algorithm to run in digital signal processing (DSP) equipment which imitates the action of the studio manager. When compressing the dynamic range of musical material, the studio manager discreetly raises the level of quiet passages in the music, and anticipates an approaching fortissimo by slowly (and, hopefully, unobtrusively) reducing the level prior to the musical climax. The intention is to compress the dynamic range whilst preserving the impact of a dramatic change in the programme dynamics (e.g. that caused by a crescendo or subito fortissimo). A DSP has neither the studio manager’s knowledge of music nor the ability to read a musical

score, but it can gain prior experience of the programme content by delaying the programme in memory whilst making the necessary level adjustments.

The original algorithm looked 3 seconds ahead into the audio data. With such an arrangement, it could anticipate impending changes in level and start to make gradual gain changes. The figure of 3 seconds was chosen as a compromise between better anticipation and ease of operational use. If a shorter delay is used there is less warning of the changes in level, so more abrupt reductions in gain sometimes have to be made. However, the requirements of “live” broadcasting are likely to preclude the possibility of using delays as long as 3 seconds, and subsequent development of the algorithm has enabled delays as short as 30 milliseconds to be used.

The DRC system was originally conceived as a self-contained dynamic range controller, for use with conventional FM transmitters [14]. In DAB, it comprises a broadcaster’s DRC generator and a receiver gain control operating in the manner already described for the Telekom DRC system, in the situation shown in the block schematic diagram of Fig. 4. The audio samples are transmitted unmodified and the DRC generator supplements these with the DRC signal, comprising the gain

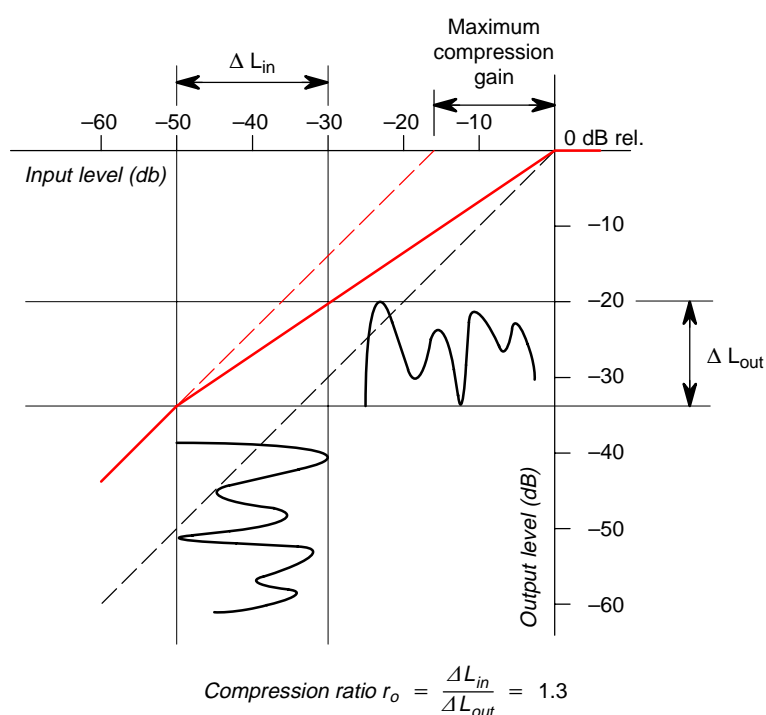

Figure 6  
Operational characteristic of Telekom system.

0 dB<sub>rel</sub> is relative to the Permitted Maximum Signal level (ITU-R).

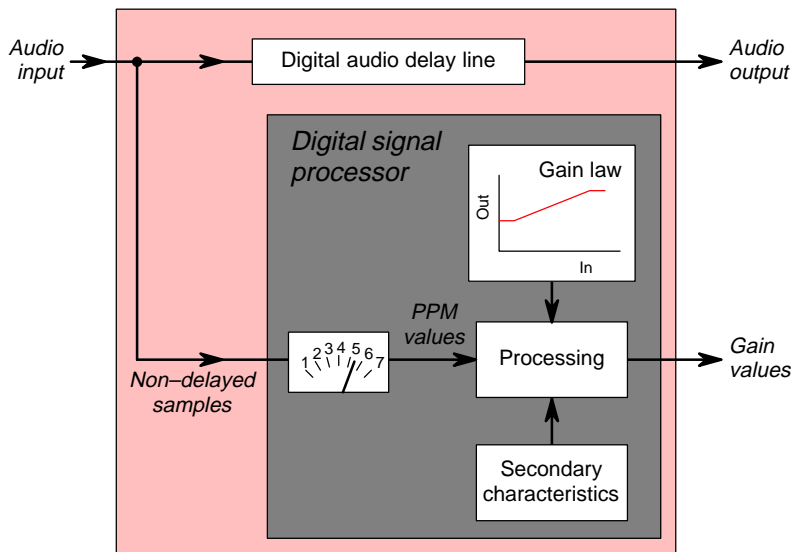

Figure 7  
Block schematic  
diagram of the BBC  
DRC signal generator.

values derived by the processor, which are suitably encoded for transmission with the audio. A diagram of the DRC generator is shown in Fig. 7.

The DSP in the DRC generator is programmed to analyse the undelayed audio samples and derive a succession of peak-programme meter (PPM) level indications, one every quarter of a second. The value of gain (or attenuation) that would need to be applied to the input signal to bring the peak level in the time window provided by the delay to the desired level is derived from the gain law. This law is based upon the simple characteristics shown in Figs. 3a to 3c, but is significantly more complicated. Although the gain law may be specified at only a few discrete points, the DSP interpolates linearly between them to calculate the desired output signal level for any input signal level, and indicates the required gain values to the receiver via the DRC signal. The DSP aims to have the gain at the required value by the time the programme peak in the window appears at the output of the delay; this will not always be achieved, however.

The maximum rate at which the gain can change unobtrusively to that required is preset in the DSP program. A figure of just over 1 dB per second was used initially in the BBC's experimental implementation. Listening tests have shown that the increases in gain intended to raise the level of quiet signals were more obtrusive than reductions in gain. In one item of choral music the gradual increase in gain applied to a quiet passage gave the disturbing impression that the whole choir was creeping forwards. It was necessary to reduce the rate of gain increase to about 0.5 dB per second to overcome this effect. The maximum rate of de-

crease in gain remains at about 1 dB per second. Once calculated, the gain values are smoothed so that they do not continuously follow the smallest variations in signal level. The limit on the maximum rate of reduction of gain is ignored if the output level would otherwise exceed a predetermined maximum level, to ensure that the listener is not subjected to excessively high levels in the reproduced programme. If the system is being used as a self-contained controller (e.g. for the pre-compression of programmes for VHF/FM broadcasting) this would prevent overloading or "clipping" later in the broadcasting chain, or over-deviation of the transmitter.

A limit is set to the maximum gain which can be applied to the very quietest signals. There are two reasons for this. The first is that quiet sources, such as soft singing, can sound unnatural when reproduced at an excessively high level. The second is that background noise may be raised to the level where it becomes obtrusive.

The algorithm implemented as described above works well. However, some impairments were noticed on certain critical types of material. These led to the addition of some secondary characteristics to the algorithm using the longer delay, to remove the impairments.

One item of music which revealed unnatural sounding impairments was a passage of piano music containing a gradual diminuendo. As the level of the input signal fell, the gain applied was increased. In this case, a peculiar sustaining of the decay of individual piano notes was noticed, during the diminuendo. Each decay took fractionally longer to extinction than was expected, and after a short period of listening the effect became very noticeable. Similarly, when there were very small crescendi in an item of music in which the programme level was generally rising, the effect of the gradual reduction in gain which was occurring tended to obliterate them.

The secondary characteristics which were added were as follows. Whilst the gain is being increased, if two or more successive quarter-second blocks of samples show decreasing level, then the gain is not increased during those blocks. While the gain is being decreased, if two successive quarter-second blocks show increasing level, then the gain is not reduced during those blocks (although priority is given to ensuring that the output signal does not exceed the predetermined level at which downstream equipment would introduce limiting).

The most obvious effects of the processing which remain occur when a very loud passage follows a

very quiet one. Under these circumstances, the dynamic range controller has to change from maximum gain to maximum attenuation during the look-ahead time provided by the delay, to prevent the signal peaks exceeding the limiting level of equipment later in the broadcasting chain. To do this it has to override the limit on the maximum rate of gain change. Even when this happens, the adjustment of the programme level is relatively unobtrusive, and because the gain can increase at only a low rate there are none of the repeated changes of gain at the programme peaks which characterise fast-acting limiters or compressors and give rise to some of the more objectionable impairments associated with this type of device.

#### ■ 4.4. The receiving side

According to the DAB Specification [3], a common and simple receiver concept realises the necessary DRC functions. These functions do not depend upon the type of algorithm in the DRC signal generator used at the transmitting side. The same options for listening to the uncompressed programme, the programme with the nominal degree of compression and the programme with a greater degree of compression are always available. As mentioned above, the more compression that is applied to the programme, the greater the risk of impairing the sound quality. This should be borne in mind together with factors such as the reproduction conditions when determining the degree of compression to be applied.

##### ■ 4.4.1. Regeneration of the DRC signal

The DRC data is de-multiplexed from the PAD area, and a linear interpolation regenerates a continuous signal to control the gain of the audio channel, in order to match the dynamic range of the received programme to the individual listener's needs. Using characteristics as described above,

the maximum gain change in the compression mode will be about 15 dB. If the error protection applied to the PAD fails, specifically defined limiting characteristics for the rate of gain change will protect the compressed audio signal against severe impairments.

##### ■ 4.4.2. Controlling the dynamic range using gain adjustments

There are at least two possible ways to realise the gain variation under the control of the DRC signal.

The conventional way is to use a simple multiplication in the digital domain, or a voltage-controlled or digitally-controlled amplifier (VCA or DCA) at the analogue end of the receiver to realise all necessary gain adjustments (DRC, manual and automatic volume control and other gain-related features such as the balancing of music and speech loudness).

Another solution which could readily be implemented in Layer 2 integrated circuits [17] uses the existing functions of the source decoder to modify the scale factors in accordance with the DRC data. Fig. 8 shows in more detail those receiver functions needed for dynamic range control.

The listener may choose to use the DRC data unmodified, and accept the degree of compression for which the broadcaster's DRC data generator is adjusted, or may modify the DRC data to increase or decrease the degree of compression. If no compression is selected, the audio programme is reproduced with the dynamic range as broadcast. If the listener selects the nominal compression, the audio programme is reproduced with the degree of dynamic compression set by the broadcaster. It is likely that the maximum compression ratio available to the listener makes sense only for poor reproduction conditions (e.g. in a car) and for certain types of programme, because some impair-

Figure 8  
Dynamic range control for DAB: Receiving block diagram.

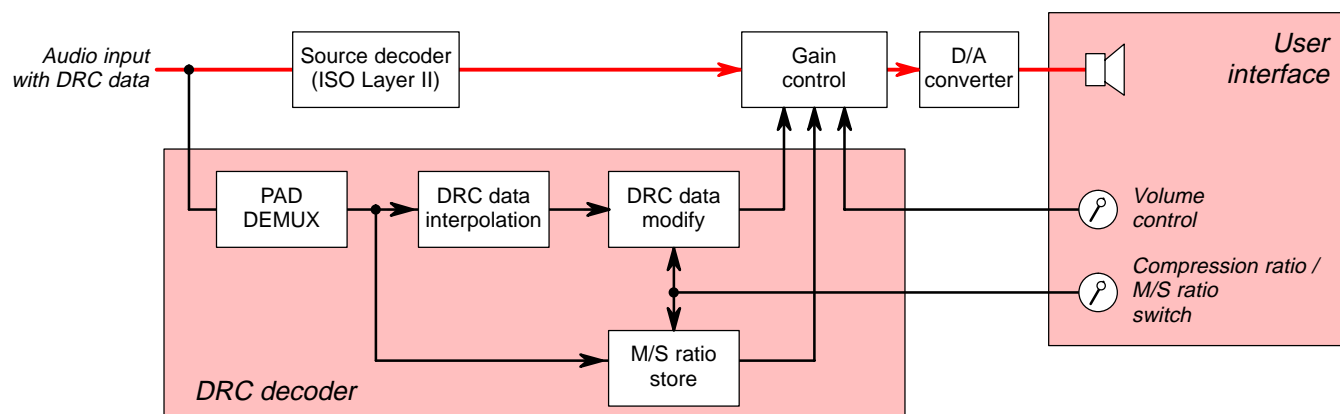

ment of the sound quality is inevitable. A receiver which is required to compress the dynamic range needs only to provide the gain signalled to it via the DRC data. Thus the same receiver is suitable for use with both Telekom and BBC systems.

#### ■ 4.5. Benefits

Benefits of a DRC system with transmitted control signal are:

- because the control data generation algorithm(s) will not be specified in detail, there will always be the opportunity for the broadcaster to improve the performance of the DRC data generation without the need to change the receiving equipment (“improvability”);
- the broadcaster is always able to check the results expected at the receiving end by monitoring at the studio end;



**Wolfgang Hoeg** studied electrical engineering and acoustics at the Technische Hochschule Dresden (Germany) and received a Masters degree (Diplom-Ingenieur) in 1959, followed by a postgraduate degree as a specialist engineer for automation of telecommunication technology in 1974. In 1959 he joined the Rundfunk- und Fernsehtechnisches Zentralamt (RFZ) in Berlin where he was in many research projects in the fields of psychoacoustics, sound studio technology, sound reinforcement and sound transmission systems, and especially with the development and introduction of stereophonic broadcasting and automation of studio processes. Since 1991, he has been with the research and development center of Telekom (FTZ Berlin), in the Research Group for New Sound Transmission Systems. Now he is dealing with multi-channel sound systems and special aspects of DAB.

For many years, Mr. Hoeg was involved in the activities of international standardization organizations, including the former OIRT, the ITU Radiocommunication Bureau, and the Eureka 147 DAB project. He is Chairman of EBU Specialist Group G1/LIST (Listening conditions).



**Neil Gilchrist** joined BBC Designs Department in 1965, after graduating from Manchester University (UK) with an Honours degree in Physics and Electronic Engineering. He moved to Research Department in 1967, working initially on various radio-frequency projects. Since 1976 he has been working mainly in the field of digital audio, on analogue/digital conversion, NICAM, sampling-frequency synchronization, standardization activities and collaborative projects in RACE and Eureka. He is currently Project Manager in Studio Section of Research and Development Department.

Since 1981, Mr. Gilchrist has represented the BBC on EBU Sub-group V3 (Sound). He is active in the British Section of the AES, was formerly Chairman of CCIR Interim Working Party 10/6 dealing with the international exchange of sound programmes, and he represents the United Kingdom in Working Party 10C of the ITU Radiocommunication Bureau.

In 1989 he joined the Eureka 147 Digital Audio Broadcasting project, where he represents the BBC in the group concerned with audio source coding.



**Herbert Jünger** studied electrical engineering at the University of Rostock (Germany) and received a Masters degree (Diplom-Ingenieur) in 1974. He joined the electronics industry as a design engineer in measurement instruments.

Based on his interest in music and sound recording, he has been involved in many aspects of professional audio since 1985. His first products in this field were developed for the public broadcast organization in the former East Germany.

In 1990 he founded Jünger Audio GmbH in Berlin as a private company specializing in the development of high-performance dynamic range processors and related products. He has developed new principles of inaudible dynamic range reduction for applications with digital signal processors.

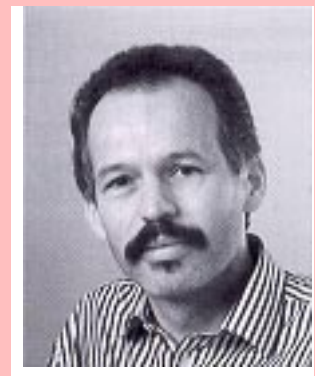

**Heinrich Twietmeyer** studied physics at the universities of Hamburg and Münster (Germany). In 1975 he joined the IRT where, since 1985, he has been the head of the section for Sound and Data Transmission Systems/Channel Coding. His current research interests are concentrated on new data services for digital broadcast systems such as DAB and on contribution and distribution technologies related to DAB.

Mr. Twietmeyer is involved in the Eureka 147 DAB project, especially in the field of data services. ▶

- there is the potential to use the same algorithm or DRC signal to compress the programme signals at the studio side for transmission via other systems, for instance FM or AM broadcasting (“universality”).
- the complexity at the receiving side will be very low, because no “intelligent” analysis is needed, and most of the processing needed is already available in the receiver.

#### ■ 4.6. Music/Speech loudness control

In addition to the DRC system described, a Music/Speech loudness control (MSC) can balance the relative programme loudness to the listener’s individual taste. There is the option to signal four states of the so-called M(usic)/S(peech) flag:

- 1 programme content = music
- 2 programme content = speech
- 3 programme content = not signalled
- 4 reserved for future use (e.g. for a programme containing music and speech with artistically well-balanced levels, for instance drama or a musical).

This M/S flag information can be generated at the studio side automatically (e.g. derived from the corresponding channel fader at the mixing console). As an item of programme-related data, the information is transported within the PAD, and may be used at the receiver to control the output signal level (volume) in a predetermined manner, probably in a level range of about 0 to –15 dB, either to enhance the music, or the speech (or nothing).

### ■ 5. DRC hardware

#### ■ 5.1. Control algorithm problems

The basic conflict in a dynamic range control system is to handle rapid changes of the input signal whilst minimising side effects such as gain “pumping” and signal distortion, as explained earlier. The advantage of the systems described in this paper is that the dynamic parameters are variable and are adapted to the incoming programme signal. The control algorithms implemented in the digital signal processor are very complex, and they continually optimise a multitude of different parameters.

Because the DRC data is transmitted discontinuously in time intervals of one DAB frame (24 ms), to avoid overshoots (i.e. brief periods in which the reproduced signal is excessively loud) in the output

<i>Digital input/output</i>		
	Sampling rate	30 – 50 kHz (self-synchronizing)
	Audio data word	16 bits (20 bits in bypass mode)
	Audio interface	AES/EBU, professional and consumer (XLR connector)
	DAB sync (24 ms)	TTL (BNC connector)
	DRC data	HC-MOS (sub-D 9 connector)
<i>Analogue output</i>		
	D/A converter	Stereo, 18 bit, 64 times oversampling
	Output level	Adjustable from 0 to 16 dBu, balanced
	System dynamic range	106 dB
<i>DRC data generation (coder)</i>		
	Input level	PMS = –9 dBFS (EBU Rec. R68)
	Processing time	24 ms (1 DAB frame)
	Overall time delay	48 ms
	Compression ratio	$r=1.3$ for input levels > –50 dB <sub>ref</sub>
	Attack time / Release time	Variable (programme dependent)
	Data rate	0.25 kbit/s (6 bit / 24 ms)
<i>DRC decoder</i>		
	Compression ratio	Adjustable from 1.0 to 2.0
	Compression gain (dependent on ratio and actual DRC signal)	typical: 0 to 16 dB (for $r=1.3$ ) maximum: 0 to 20 dB (for $r=2.0$ )
	Gain difference, Music/Speech	Adjustable between 0 and $\pm 10$ dB
<i>Dimensions</i>		19 inch 1U

from the receiver, it is necessary to have a look-ahead time of one complete DAB frame in which to analyse the level of the signal. Self-contained dynamic range controllers for use with VHF/FM transmission do not have to work with discontinuous control signals. However, a delay is still needed in the signal path so that the incoming audio signal may be examined prior to the application of any changes in gain. This delay is 24 ms in the Telekom DRC process; the BBC process requires 30 ms, but may be implemented with a longer delay.

#### ■ 5.2. The Telekom DRC signal generator and decoder hardware

The hardware realisation of the Telekom DRC signal generator and decoder was first presented at the 2nd Radio Montreux Symposium, 1994 [15]. Similar items of equipment are used for DAB and for FM broadcasting. They are based on the well-known professional digital dynamics processor hardware<sup>2</sup>. The equipment is designed to process digital audio signals delivered in AES/EBU for-

Table 2  
Typical technical characteristics of the Telekom/Jünger DRC coder and decoder model for DAB

2. Digital dynamics processor model d01 (Jünger Audio Inc. Berlin, Germany) [18].



Figure 9  
DAB DRC coder  
(Telekom/Jünger  
Audio).

mat. The input signal arriving via the XLR connector and a balanced transformer is synchronized automatically, and the sample rate is detected and displayed on a corresponding LED. A 32-bit floating-point DSP performs the processing. The DSP carries out the function of DRC data generation, including the necessary delaying of the signal. It measures the digital input and output signal levels and displays the gain change. In the bypass mode, the digital signal is switched directly to the output, without any processing. As this function bypasses the internal processor, no delay is introduced in this mode of operation.

Additionally, an analogue output signal is available, which allows audio monitoring of the dynamic range processing. It is generated by a digital-to-analogue converter with a resolution of 18 bits per sample, and fed to balanced output drivers.

Figure 10  
User interface screen  
display of the  
laboratory version of  
DRACULA.

Table 2 shows some important technical characteristics of the existing device. Fig. 9 shows the front panel of the DRC signal generator.

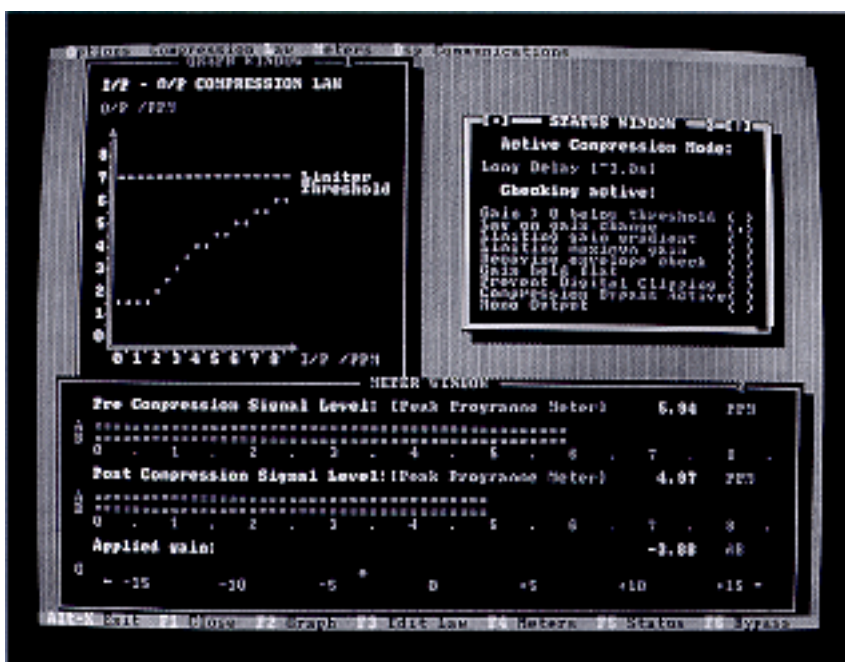

### 5.3. The BBC DRC signal generator and decoder hardware

The BBC dynamic range controller, which has been termed “DRACULA”<sup>3</sup>, has been implemented in two 32-bit processor systems. It is capable of functioning as a DAB DRC signal generator or as a self-contained dynamic range controller. The laboratory implementation is in a general-purpose DSP32C-based floating-point system<sup>4</sup>, and this is capable of running the algorithms with either a long delay or a short delay. A DRACULA processor based on a DSP 56000 series DSP and running the short-delay algorithm, is being manufactured by a British company<sup>5</sup>.

In order to enable operators and experimenters to adjust the parameters of the laboratory version of DRACULA with ease, controlling software has been developed to run on a laptop PC (Personal Computer). The PC is connected to the dynamic range controller via an RS 232 serial interface.

The user is presented with a screen display on the PC comprising three windows, a graph, meter display and a status window. These are shown in Fig. 10. The meter display, at the bottom of the screen, gives input and output stereo PPM level readings in the form of bar-graph indicators and also as numerical values. It also indicates the gain, expressed in dB, being applied to the audio signal. The status window at the top right-hand side shows the look-ahead delay being used, and indicates which of the facilities listed are being used. At the top left-hand side, the graph window displays the compression law which is in use. At the very top of the screen in Fig. 10 is a menu bar. The user has the option to change parts of the display or some of the parameters of the controller, using the menu [14].

3. Dynamic Range Audio Controller with Unobtrusive Level Adjustment.
4. The laboratory hardware was made by the Fraunhofer Institute for Integrated Circuits, Erlangen, Germany.
5. Pro-Bel Ltd. Reading, Berkshire, UK.

## 6. Other applications

The DRC system with transmitted control data has been developed principally for use in a Eureka 147 DAB system. As the additional data capacity required for the DRC signal is very low, this system could also be used for other digital audio transmission systems, such as:

- digital video broadcasting;
- digital medium-wave broadcasting;
- multichannel sound transmission systems (e.g. MPEG2) with or without accompanying picture;
- other future digital transmission or recording formats.

A self-contained controller for dynamic range control is needed for the existing VHF/FM broadcast services, because of the smaller dynamic range capability of the FM channel compared with the source programme dynamic range. Either of the DRC systems described in this paper would be suitable for pre-compression of the audio programme. A compression ratio of 1.3 has been found suitable for the Telekom system, in this application [19], so that it gives about 15 dB reduction in the dynamic range of the programme. Preliminary studies with the BBC's DRACULA system have indicated that this, too, operates unobtrusively when effecting this degree of compression.

## 7. Conclusions

For many years broadcasters have had to work with a medium which does not have the capability to carry many types of source programme with the original dynamic range. They have had to employ skilled operators, and to use equipment which all too often impairs the audio quality in order to effect the necessary reduction in dynamic range. The introduction of digital audio broadcasting (DAB), with the capability of conveying programmes to the listener with a wider dynamic range, will not solve the problem. Not all listeners will want, or be in a position to appreciate, the full dynamic range of a symphony orchestra or a choir, for example. There will still be the need for some form of dynamic range control (DRC).

Using modern digital signal processing (DSP) techniques, and drawing on the experience obtained by broadcasters over many years, it is now possible to effect the control of programme dynamic range virtually unobtrusively, and without

the need for a human operator. Two approaches to dynamic range control (DRC) have been described, and both are suitable for use either in a self-contained controller (e.g. for conventional VHF/FM broadcasting) or in a DRC signal generator providing optional compression at the receiver in a DAB system, via the broadcast programme associated data (PAD) channel.

The satisfactory balancing of the loudness of different types of programme, particularly music and speech, depends principally upon the requirements of the listener. In conventional broadcasting it has never been possible to satisfy every listener. However, with DAB it will be possible to let individual listeners determine the balance to be reproduced in their own environments, using music/ speech control (MSC) information, signalled in the PAD.

### Acknowledgements

The authors are indebted to Telekom FTZ, the IRT and the BBC for permission to publish this paper. They also wish to thank their colleagues in the Eureka 147 DAB project for their support and encouragement.

## Bibliography

- [1] Riley, J.L.: **The DAB multiplex and system support features**  
EBU Technical Review No. 259 (Spring 1994).
- [2] Draft Revision of Recommendation ITU-R BO.789, Document 10/74E, Geneva (December 1993): **Digital sound broadcasting to vehicular, portable and fixed receivers for BSS (sound)**
- [3] Draft European Telecommunication Standard prETS 300 401 (1994): **Radio Broadcasting System; Digital Audio Broadcasting (DAB) to mobile, portable and fixed receivers**
- [4] Müller, K.: **What dynamic range does the listener wish to have?**  
EBU Review 124-A (Technical), December, 1970.
- [5] Ilmonen, K.: **Listener preferences for loudness balance of broadcasts, with special consideration to listening in noise.**  
Research Report from Finnish Broadcasting Company No. 12/1971, Helsinki (1971).
- [6] Wagner, K.: **Zu den Unterschieden der Schallwiedergabe im Auto und im Wohnbereich** (On the difference of sound reproduction conditions in a car or in the home environment)  
Report 17. Tonmeistertagung, Karlsruhe (1992).

- [7] Steffen, E.: **Untersuchungen zur lautstärkegerechten Aussteuerung von Rundfunk-Tonsignalen** (Investigations on loudness-oriented level control for audio broadcast programme signals)  
Tech. Mitt. des RFZ, 22 (1978) 3/4.
- [8] **ARD – Richtlinien für die Aussteuerung im Tonrundfunk** (Guidelines of the ARD for level control in audio broadcasting) Arbeitskommission der Hörfunkbetriebsleiter der ARD (1972).
- [9] Steinke, G.: **Das Pegelprofil in der Tonstudio- und Rundfunkübertragungstechnik** (Level profiles in sound studio technique and sound broadcast transmission chains)  
dB-Magazin für Studioteknik, Cologne (1990)1/2.
- [10] OIRT Report Nr. 28/1-II. Prague (April, 1988): **Über das Verhältnis der Lautstärke von Musik und Sprache bei Rundfunk- und Fernsehsendungen** (On the relation of the loudness levels between music and speech in radio and TV programmes)
- [11] Hoeg, W.: **Technologische Probleme bei der Automatisierung der Programmabwicklung im Hörrundfunk** (Technological problems concerning an automated programme continuity process in sound broadcasting)  
Submitted for a postgraduate degree; Hochschule f. Verkehrswesen, Dresden (1974).
- [12] Plenge, G., Spikofski, G. and Theile, G.: **Vari-able dynamic range: A method for improving the sound broadcasting and television service**  
EBU Review – Technical No. 218, August 1986.
- [13] Million, A., Krause, M.: **Intelligenter automa-tischer Kompander mit großen Zeitkons-tanten** (An intelligent automatic compander with large look-ahead time constants)  
NTG-Fachberichte 91 (1986).
- [14] Gilchrist, N.H.C.: **Dynamic Range Control for DAB**  
Proceedings, 2nd International DAB Symposi-um, Toronto (March, 1994).
- [15] Hoeg, W., Twietmeyer, H. and Jünger, H.: **Additional data services for DAB: Dynam-ic Range Control (DRC)**  
Proceedings, 2nd International Radio Symposi-um Montreux (June 1994).
- [16] Azizi, S.A.: **Digital Dynamic Range Proces-sor for car audio applications**  
94th AES Convention, Berlin (March, 1993), Preprint 3463.
- [17] Theile, G. and Link, M.: **Low-complexity Dy-namic Range Control system based on scalefactor weighting**  
94th AES Convention, Berlin (March, 1993), Preprint 3563.
- [18] Fa. JÜNGER AUDIO: **Digital Dynamics Pro-cessor – Model d01: Operation Manual**  
Berlin (November 1992)
- [19] Wagner, K.: **Dynamik von Musik bei Pro-duktion und Sendung** (Dynamic of music programmes in production and broadcast pro-cesses)  
J. radio fernsehen elektronik, Berlin 40(1991)6.

## IBC Award

# IBC'94

Continuing a long-standing tradition of the International Broadcasting Convention, the 1994 IBC John Tucker Award was presented to Dr. Mario Cominetti of RAI-Radiotelevisione Italiana. The Award was made in recognition of Dr. Cominetti's outstanding contribution to the establishment of standards for digital transmission systems for radio and television on terrestrial and satellite channels. His major achievements in recent years have been concerned with digital HDTV transmission by satellite and his involvement in the European Digital Video Broadcasting (DVB) project, although his keen interest in the development of digital technologies in broadcasting extends back many years, notably through his work on teletext and other forms of data broadcasting.



Dr. Cominetti graduated in physics from Turin University and followed this with a period at the Politecnico di Torino where he completed a course in electronic engineering. After spending some time as a research engineer at the Istituto Nazionale Galileo Ferraris, and later with IBM, he joined the RAI Research Centre in Turin where he is now Head of RF Technologies Division. Dr. Cominetti is Chairman of EBU Sub-group V2 (Data broadcasting).

Dr. Mario Cominetti (left) receiving the IBC Award from Mr. Stanley Baron.