

Inter-operability of digital HDTV satellite broadcasting (21.4–22 GHz) with the existing and future media infrastructure

Status of the HD–SAT project

Ch. Dosch (IRT)

The HD–SAT project began in 1992 with the objective of developing a digital satellite broadcasting system using the newly–allocated 21.4–22 GHz band and designed specifically to deliver studio–quality high–definition television programmes directly to viewers’ homes.

This status report on the HD–SAT project shows how the project has evolved over the first three years, encouraging and embracing new technologies and adapting to the rapidly–changing scenarios under development for other television broadcasting services, notably the European Digital Video Broadcasting project.

1. Introduction

The World Administrative Radio Conference (1992) held by the ITU in Torremolinos, Spain, from February 3 to March 3, 1992, allocated the band 21.4 – 22 GHz to the Broadcasting Satellite Service (BSS) in ITU Regions 1 and 3 (for the Americas, i.e. ITU Region 2, the band 17.3 – 17.8 GHz was allocated). The band can be fully used by that service from April 1, 2007. Before that date special interim procedures apply (Resolution 525 of WARC–92).

Much research work had been carried out and reported by the CCIR prior to this Conference in order to demonstrate the technical feasibility of such a direct broadcasting satellite (DBS) service for “wide–RF band HDTV” (i.e. studio–quality HDTV) in the 20–GHz frequency range [1]. The research project HD–SAT has been able to work with the firm knowledge of this allocation and to concentrate on the specific band allocated.

This article cannot cover the full scope of the project; it concentrates on the multiplexing, transcoding and transmission aspects.

2. Aims and structure of HD–SAT

As described in [2], the European Broadcasting Union (EBU) was able to organize a major technical demonstration of bit–rate reduced digital HDTV in studio quality for the delegates of WARC–92 [3]. This 140 Mbit/s transmission, carried out over a satellite simulator, marked the starting–point of the RACE¹ HD–SAT project, which is fully named “Bandwidth efficient coding and modulation for wideband HDTV applications supported by satellite and cable networks”. It stretches over four years from 1992 to 1995.

HD–SAT is a consortium of eleven partners from industry, broadcasters and research organizations. The project is partially funded by the Commission

1. RACE: Research and technology development in Advanced Communications technologies in Europe

Original language: English
Manuscript received 11/7/94.
Adapted from a paper given
by the author at the 16th
Symposium of the Fernseh– und
Kinotechnische Gesellschaft,
Nürnberg, 16–20 May 1994.



of the European Union within the framework of the RACE programme and enjoys additional support by sponsors and sponsoring partners.

Participants in the HD-SAT project (RACE 2075) 1992-1995

Partners

Alcatel Espace (Project Leader)	ATES	F
Alenia Spazio	Alenia	I
Cable Management Ireland Ltd. Star Telematics Ltd.	CMI	IRL
Cable Management Intern. Services		
Centre Commun d'Etudes de Télédiffusion et Télécommunications	CCETT	F
Institut für Rundfunktechnik	IRT	D
RAI-Radiotelevisione Italiana	RAI	I
Télédiffusion de France	TDF	F
Alcatel-Telettra	Telettra	F
Thomson-CSF/Laboratoires Electronique de Rennes	Thomson/LER	F
University of Salford	Salford	UK

Sponsoring Partners

British Broadcasting Corporation	BBC	UK
European Broadcasting Union	EBU	

Sponsors

DBP Telekom		D
Tetespaio		I
European Space Agency	ESA	

Encouraged by the new frequency allocation of WARC-92 to the broadcasting satellite service in the band 21.4 – 22 GHz in ITU Regions 1 and 3 (for America the band 17.3 – 17.8 GHz was allocated), the project concentrates on the technological development of this 21-GHz frequency range for digital HDTV satellite broadcasting. Of course, the main emphasis is on technical questions but economic, standardization, planning and regulatory issues also play an important rôle. Care is taken not to neglect the inter-working of a future HD-SAT service with other digital services in the future multi-media landscape. In addition to satellite transmission, solutions are being developed for the compatible translation of the signal to serve existing coaxial cable networks and wireless video distribution systems (MMDS), as well as to assure the inter-operability of an HD-SAT signal with future synchronous digital hierarchy (SDH) and asynchronous transfer mode (ATM) networks (commonly referred to as “Broadband-ISDN”). The common receiver concept, presented previously [2], is being developed further in order to take into account digital terrestrial HDTV/TV reception as well as DTH/DBS satellite transmissions in the 11/12 GHz frequency range². The HD-SAT studies also cover critical components of a 21-GHz broadcasting satellite, such as transmit antennas,

2. DTH: direct-to-home satellite transmissions in the parts of the 11/12-GHz spectrum allocated to the fixed satellite service (10.7–11.76 GHz and 12.5–12.75 GHz).

TWT amplifiers, high-power output multiplexers etc. and they also include concepts for cost-effective 21-GHz satellite home receivers.

The objective of this RACE project is eventually to transmit studio-quality HDTV including multi-channel sound and new powerful data services, using a baseband data-rate of 45 Mbit/s. The sound coding uses the MUSICAM system at a data-rate of about 100 kbit/s per monophonic sound channel and 384 kbit/s per five-channel surround sound (MPEG-1 Layer II and MPEG-2, respectively) [4].

The work of the Consortium is following two tracks. On the one hand, the characteristics of a high-quality HDTV service in the 21-GHz range are being specified; on the other hand, the project is undertaking technical development work (leading towards a system demonstration) to the extent permitted by the constraints which are set by the predetermined timeframe and the available financial resources.

3. System concept

Today, satellite broadcasting of digital television services has become a reality in the United States of America; in Europe such a service will start in 1995. The video quality is broadly defined as [5,6]:

- LDTV (Limited Definition Television according to MPEG-1) with 1.2 – 1.5 Mbit/s;
- SDTV (Standard Definition Television according to MPEG-2) with 4 – 6 Mbit/s;
- EDTV (Enhanced Definition Television according to MPEG-2) with about 10 Mbit/s;
- HDTV (High Definition Television according to MPEG-2) with data rates from about 24 Mbit/s.

Broadly, LDTV will be perceived as being similar to VHS recordings, SDTV similar to PAL and SECAM, while EDTV will represent the display quality of an ITU-R Recommendation BT.601 studio signal and will also provide the option of a 16:9 aspect ratio. These developments must be taken into account by the HD-SAT project. As previously stated [2], an HD-SAT signal must allow for:

- individual reception with antennas of 60–90 cm diameter;
- cable reception;
- MMDS-reception;
- interworking with the B-ISDN.



In order to maintain virtual studio-quality when displaying the HDTV signal, relatively high data-rates are still required, even when applying an efficient data-reduction technique such as the one defined by MPEG-2 [7]. In order to achieve commonality with other digital HDTV services of lower data-rate, it should be possible to extract part of the information by accepting a somewhat lower resolution. This property may be required, for example, for terrestrial re-transmission or for recording the HDTV signal on a digital video-cassette recorder in the home. So, an HD-SAT signal must be scaleable and will thus assist the concept of a common receiver for all digital services [8]. Such a receiver could form the basis element of a multi-media centre in the home environment (see Fig. 1).

The realisation of an open architecture concept of this sort is heavily dependent on standardized video and audio coding as well as multiplexing techniques. Right from the start, HD-SAT has based its investigation on the concurrent standardizing actions of MPEG-2. HD-SAT wishes to apply the specified video coding scheme "High Level at High Profile" in order to achieve the highest possible signal quality. In Europe this corresponds to 1250 lines and 50 fields (2:1 interlace) with 1920 pixels per line (4:2:2 component coding, aspect ratio 16:9).

Fig. 1 shows the concept of the common receiver. The actual receiver (or tuner) contains the demodulator and the channel decoder. In addition it carries out the baseband error-correction (usually a Reed Solomon code). This configuration is not necessarily optimal, as special measures have to be taken in order to enable the audio and video decoders to carry out error concealment of residual uncorrected errors but, on the other hand, it does allow the modular concept to support the highest possible service commonality. The Asymmetric Digital Subscriber Loop (ADSL) permits the interactive retrieval of video information with a bandwidth of 1.5-6 Mbit/s over a twisted-pair telephone line and represents in this diagram just one option for interactive video services in the telecommunication area.

A prerequisite of a common receiver concept is the specification of a common data bus. Owing to the rapid development of the MPEG-2 system specification [9] HD-SAT was able to apply the transport stream for the "service dependent part" of the multiplex system.

While the service dependent part of the multiplex is identical for all audio-visual services and thus independent of the actual delivery media, the "transmission dependent part" must be tailored individually for each form of transmission in order to cope with the different transmission characteris-

Figure 1
Schematic example of the common receiver concept
Realisation possibly by plug-ins (similar to today's PC concept).

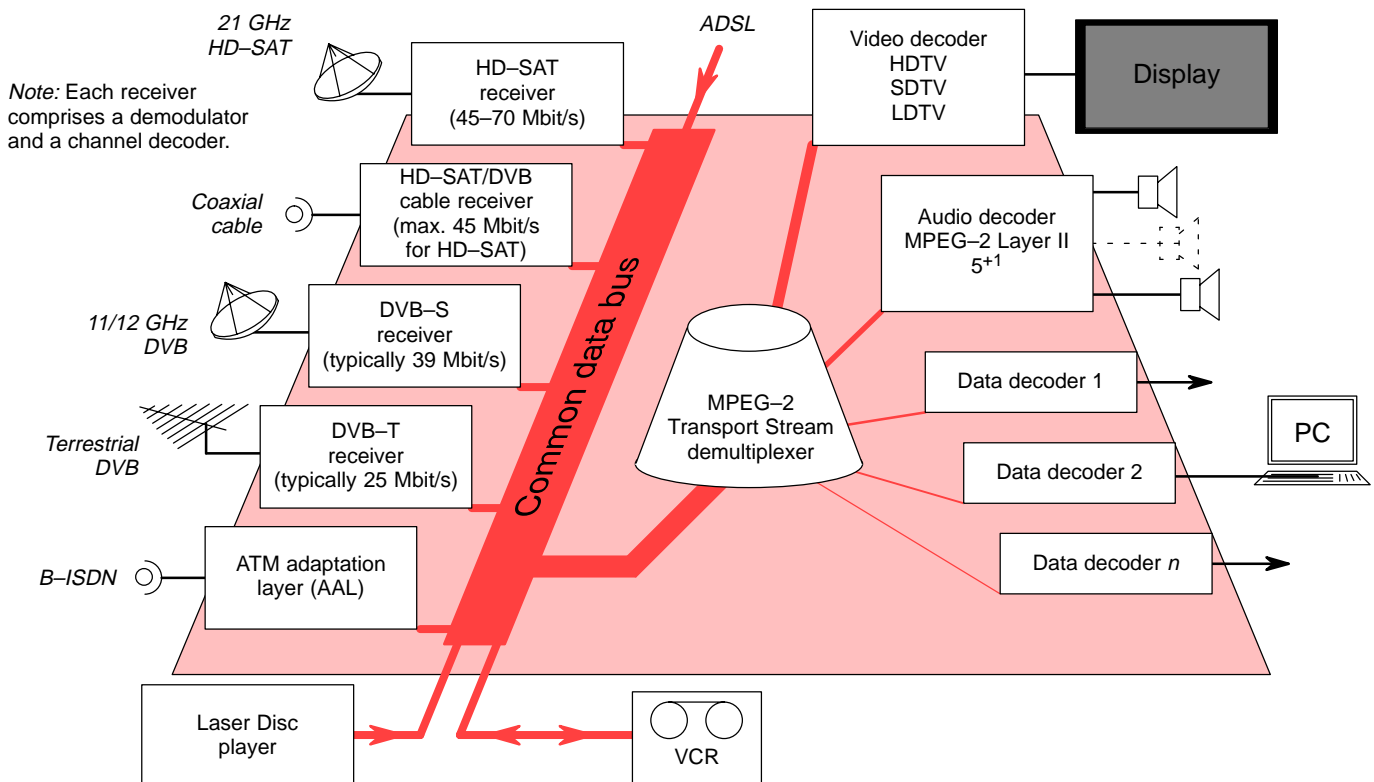

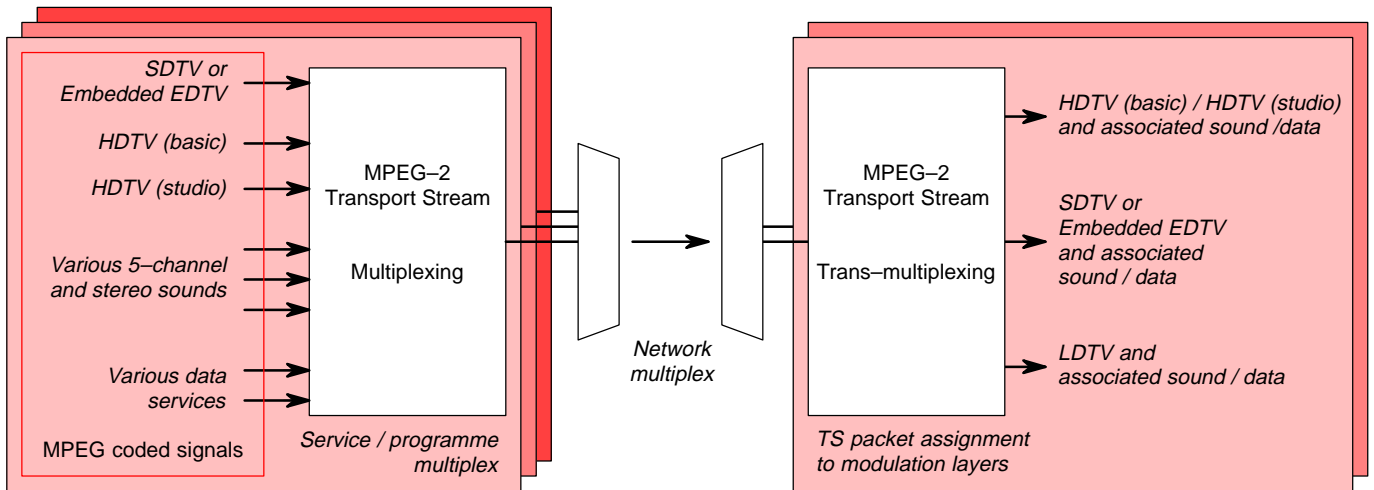
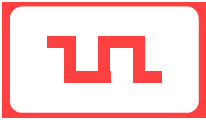

Figure 2 Example for the multiplexing of HD-SAT signals and the assignment of the various programme components to the modulation layers of the satellite signal.

tics of satellite, cable, MMDS etc. This concept of a split multiplex having a common and a transmission-specific part has also been adopted by the European initiative on Digital Video Broadcasting [10,11].

Fig. 2 gives an example for the realisation of an HD-SAT multiplex. The studio output signal contributes to form the programme multiplex. Several programme multiplexes are grouped to a service

multiplex. In a hierarchy of networks, those service multiplexes may be grouped to form network multiplexes. In the transmitting feeder-link station, the original programme multiplex is recovered and, by a process of trans-multiplexing, the individual components of the HDTV programme are delivered to the appropriate inputs of the HD-SAT channel adapters and modulators in accordance with special HD-SAT hierarchy descriptors which may be carried in the Programme Map Table

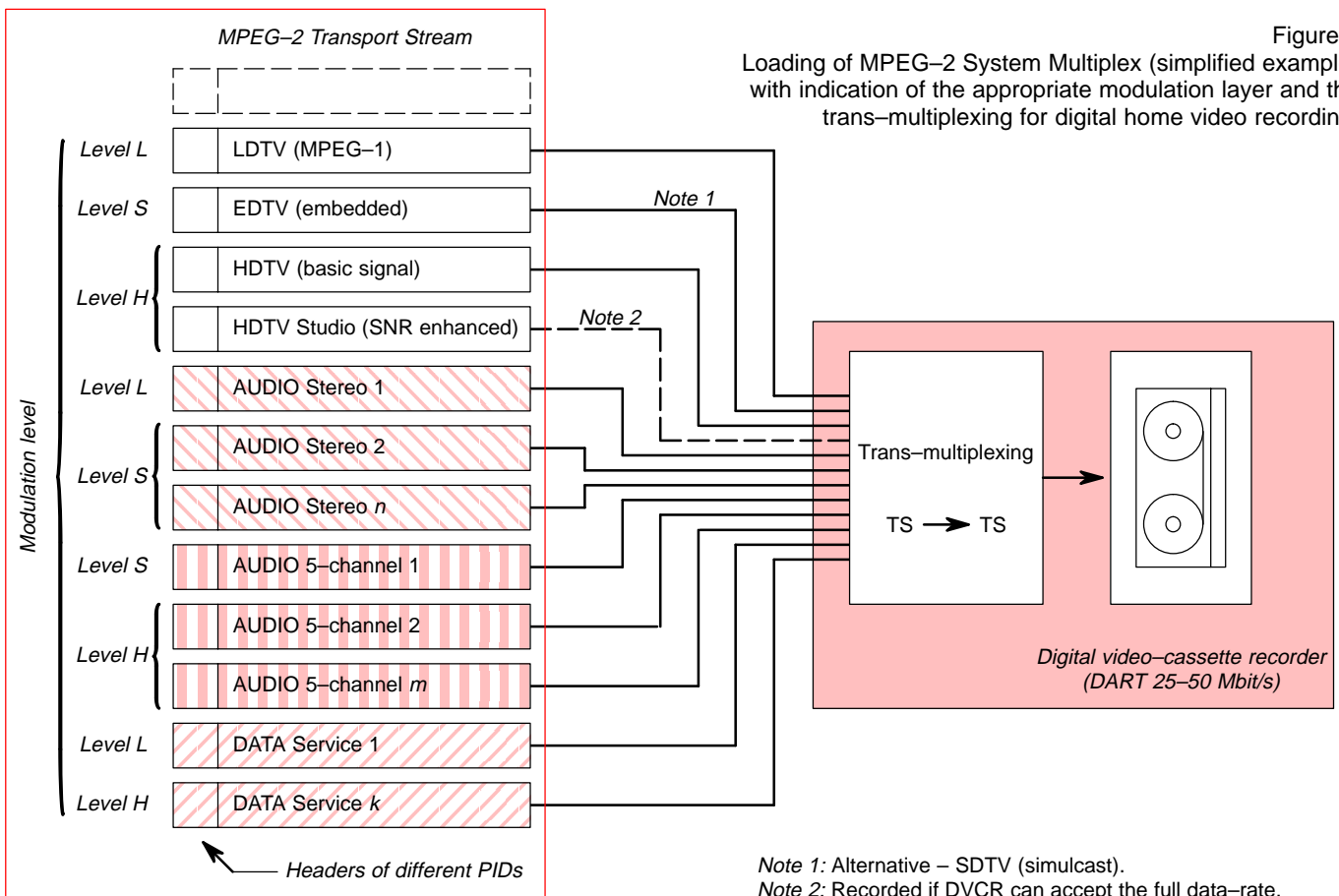

Figure 3 Loading of MPEG-2 System Multiplex (simplified example) with indication of the appropriate modulation layer and the trans-multiplexing for digital home video recording.

Note 1: Alternative - SDTV (simulcast).
 Note 2: Recorded if DVCR can accept the full data-rate.

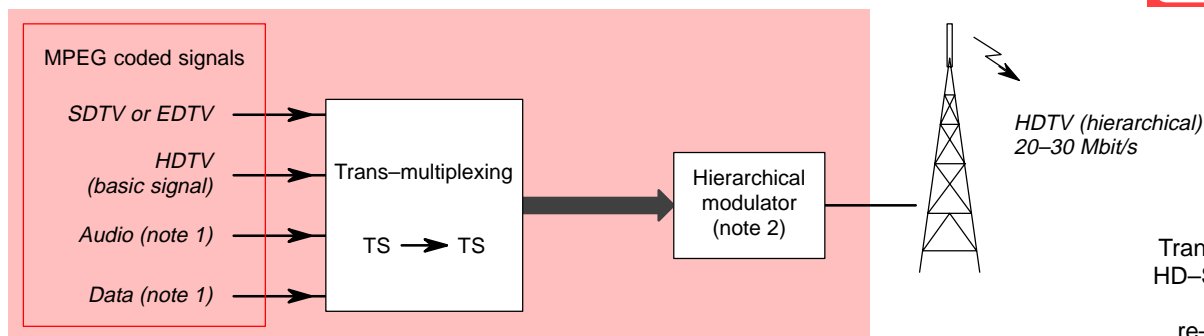

Figure 4
Transcoding of an
HD-SAT signal for
terrestrial
re-broadcasting
(example).

of the MPEG-2 System multiplex. It should be noted that all multiplexing and demultiplexing actions do use the MPEG-2 Transport Stream (TS). A trans-multiplexer for the Transport Stream therefore constitutes a key element for the future digital HDTV broadcasting service. One project partner (Thomson-CSF) intends to build such a trans-multiplexer for the system demonstration planned for mid-1995.

By combining the action of the trans-multiplexer with the three-fold spatial scalability and signal-to-noise ratio (SNR) scalability of the MPEG-2 video coding scheme, systems having different data-rate capabilities can be established. Fig. 3 illustrates this situation, taking digital video recording as an example. A first version of the digital data recorder terminal (DART), currently being developed in the framework of another RACE project, is intended for a data-rate of 25 Mbit/s. Later, this may be extended to 50 Mbit/s. A digital video cassette-recorder, capable of handling 25 Mbit/s, may thus record only the basic information of the HDTV signal (and, if applicable, the embedded SDTV or EDTV-signal) while the 50 Mbit/s version will be able to record the HDTV signal in its full studio quality. Here, the SNR scalability of MPEG-2 is exploited. Similarly, during the terrestrial re-transmission of an HD-SAT signal, the enhancement component of an HDTV-signal may be left out, whilst making use of the simulcast (or embedded) SDTV component in order

to drive a hierarchically-structured modulator (see Fig. 4) and to allow for robust portable and high-quality roof-top antenna reception. When trans-multiplexing an HD-SAT signal for subsequent cable or MMDS transmission, or when using it as input to a digital broadband communication network, a hierarchical structure may not be required thanks to the constant transmission characteristics of these media; in such a case, a simulcast SDTV or LDTV component could be left out as is shown in Fig. 5.

4. Layered modulation and hierarchical picture coding

The concept of layered modulation was presented in [2]. It provides a means of coping with the high rain attenuation in the 21-GHz frequency range. Fig. 6 gives a comparative example of such rain-fade during a heavy rain shower. The maximum attenuation rises to 15.6 dB at 12 GHz and to over 35 dB at 20 GHz. In both bands this event would have caused a total drop-out of the television service for some 15 minutes assuming, for individual reception, 4 to 5 dB of margin at 12 GHz and 10 to 12 dB of margin at 20 GHz, the latter margin being achieved by layered modulation. Indeed, the need for this layered modulation technique is the main reason why HD-SAT does make use of the scalability features of the MPEG-2 video coding system.

Figure 5
Transcoding of an
HD-SAT signal for
cable or MMDS
transmission and for
linking with a
broadband network
(example).

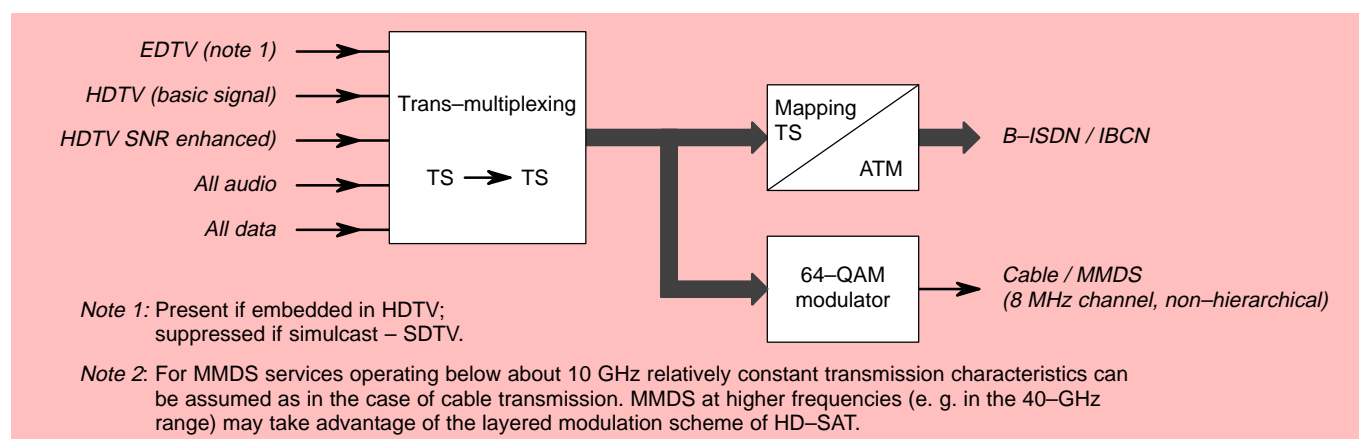

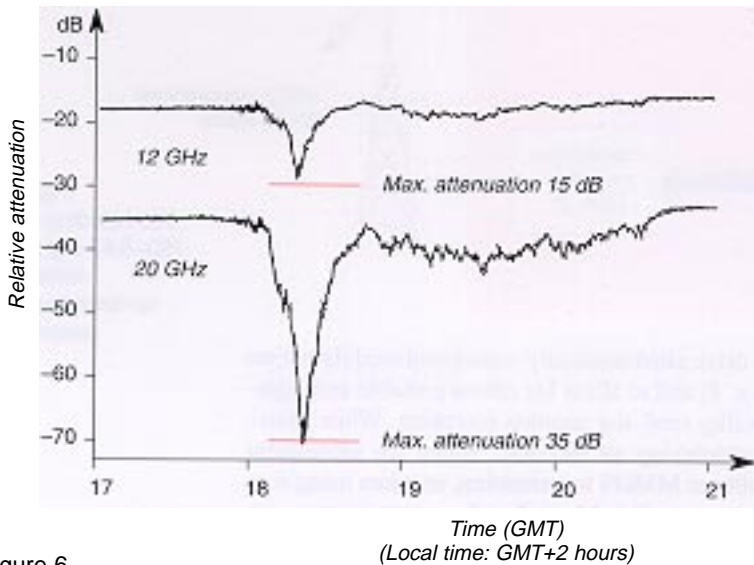
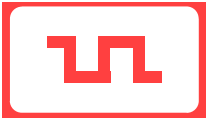

Figure 6
Relative signal attenuation at 12 GHz and 20 GHz during a summer rain shower.

In layered modulation, the individual programme components are associated with more or less robust modulation levels. During rain fades, the service does not fail abruptly, but stepwise. In this way, “graceful degradation” is obtained. Most of the time the service guarantees full HDTV studio quality. Up to a certain rain-fade, the SDTV or EDTV picture can still be decoded. If the rain attenuation increases further, an LDTV signal is available down to the minimum C/N ratio when the system fails completely. Applying this technique of layered modulation, a service continuity of 99.6 – 99.9% can be maintained for individual reception without the need for extremely high excess power in the satellite transmitter.

Fig. 7a illustrates a system proposal of the CCETT [12]. Assuming a 3 dB margin in the link budget under clear-sky conditions, a dynamic range of 12 dB is available before total drop-out of the service occurs. This proposal applies a time-multiplex of various modulation schemes. After time compres-

Figure 7a
Layered modulation by RF-multiplex technique. The dashed line represents a system with a single modulation scheme. The solid line represents the drop-out characteristics of the layered system.

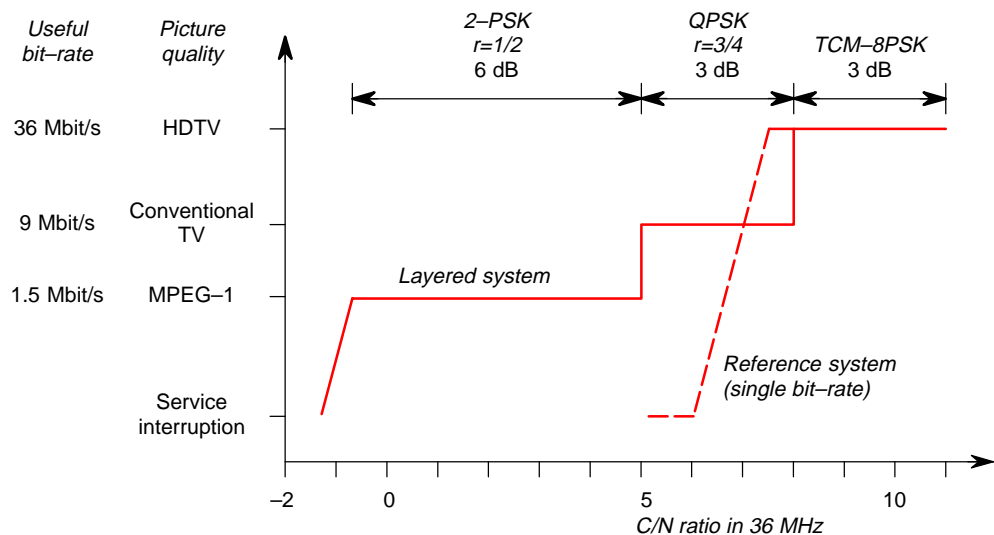
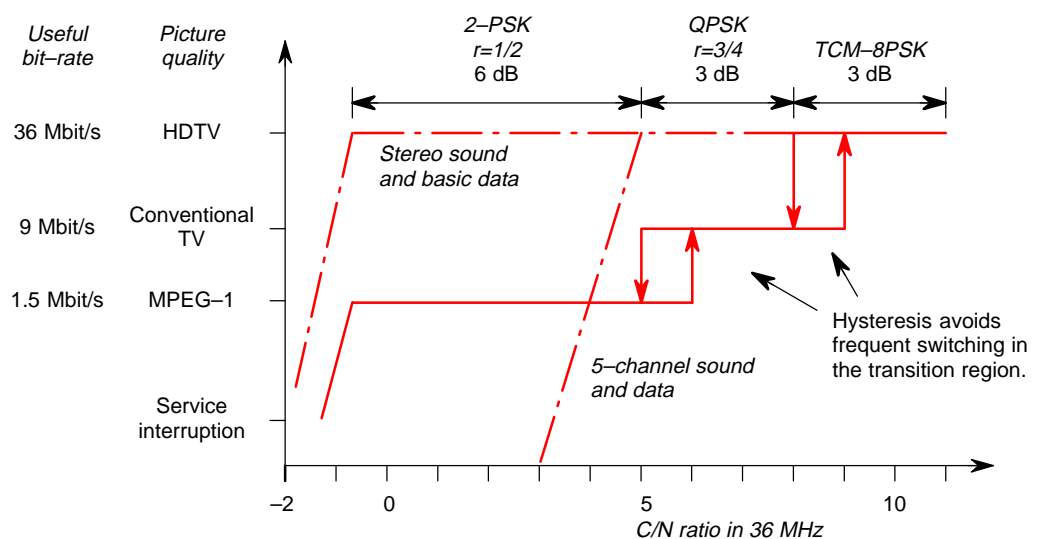

Figure 7b
Layered modulation by RF-multiplex technique. Note that the main CD-quality sound is associated with the most robust transmission layer.





sion, all the data has the same symbol rate (27 MBaud) and thus the same signal bandwidth.

As can be seen from *Fig. 7b*, the main sound channel, and the most important data channels, are associated with the most robust LDTV signal (MPEG-1). The hysteresis around the switching points avoids frequent switching of the vision format when crossing these boundaries. The transmission principle itself puts no special constraints on the “conventional television” component. It may be a separately coded SDTV signal (simulcast approach) or it may represent the embedded EDTV component of a hierarchical (i.e. spatially scaled) HDTV signal. By definition, LDTV (MPEG-1) is always coded in parallel to the other video components. *Fig. 8* demonstrates the possible increase in service continuity during a heavy rain shower when layered modulation is applied in accordance with the example of *Figs 7a* and *7b*.

An alternative to the RF multiplex is currently being studied by the IRT (*Fig. 9*). The technique is called “asymmetrical I/Q modulation”. In practice, these are punctured PSK or QAM modulation schemes providing an unequal number of eye-diagrams and thus an unequal robustness in the in-phase and in the quadrature-phase direction. While the M-QAM type is more suitable for linear channels (e.g. for terrestrial broadcasting) the punctured M-PSK exhibits less sensitivity to non-linear amplification of the kind encountered in the satellite TWTA. By further separating the phase-constellations, more than two grades of robustness can be achieved. Typical eye-diagrams for this form of modulation are shown in *Fig. 10*.

Fig. 11 illustrates how an HD-SAT signal with three layers can be generated in a simulcast approach. The various sound and data services are multiplexed with the MPEG-2 and MPEG-1 coded vision signals. The MPEG-2 transport streams obtained in this way are delivered to the channel adapters of the multi-layer modulator, as can be seen in *Fig. 12*. Each modulation layer

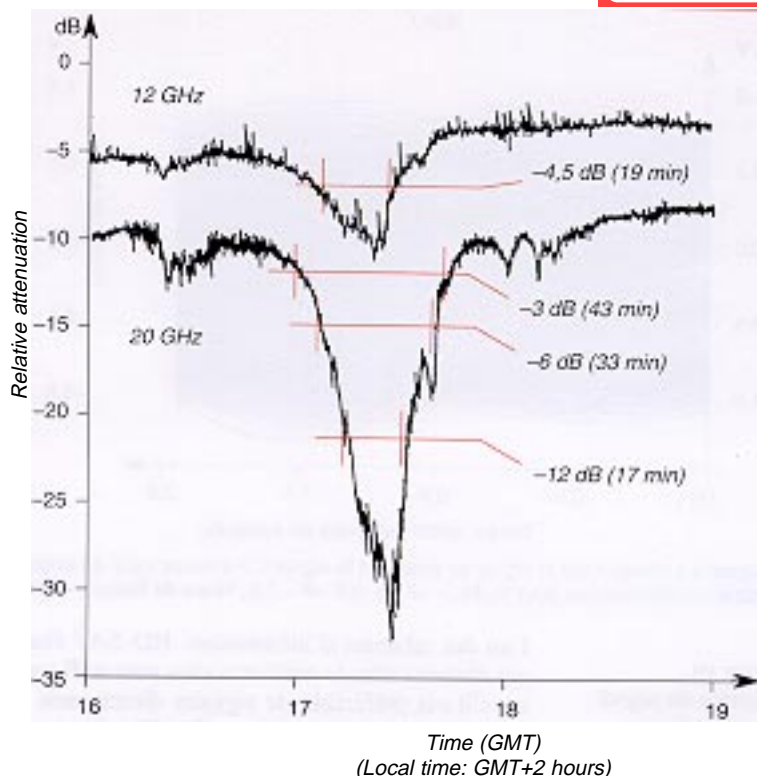

Maximum attenuation at 12 GHz: 8 dB
 Maximum attenuation at 20 GHz: 24 dB

Service availability at 12 GHz:
 – nominal service up to 4.5 dB of attenuation
 – no service beyond 4.5 dB of attenuation

Service availability at 20 GHz:
 – HDTV up to 3 dB of attenuation
 – EDTV up to 6 dB of attenuation
 – LDTV up to 12 dB of attenuation
 – no service beyond 12 dB of attenuation

Note 1: These figures correspond with the example characteristics of layered modulation as presented in *Figs 7a* and *7b*

Note 2: Due to the increase of the sky noise temperature with increasing attenuation, the reduction of C/N is slightly higher than the corresponding signal attenuation.

Figure 8
 Example of possible improvement of service continuity by layered modulation in the 20-GHz frequency range.

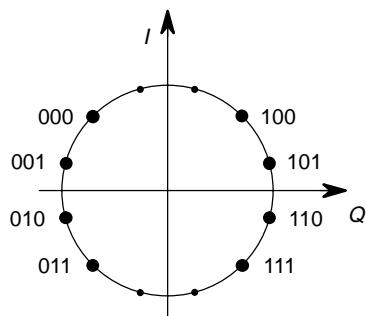

8-PSK originating from a 12-PSK constellation

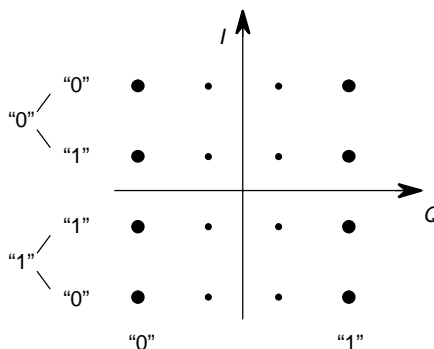

8-QAM originating from a 16-QAM constellation

Figure 9
 Layered transmission by asymmetrical I/Q modulation (examples of possible phase constellations). The bit-allocations are for illustration only.

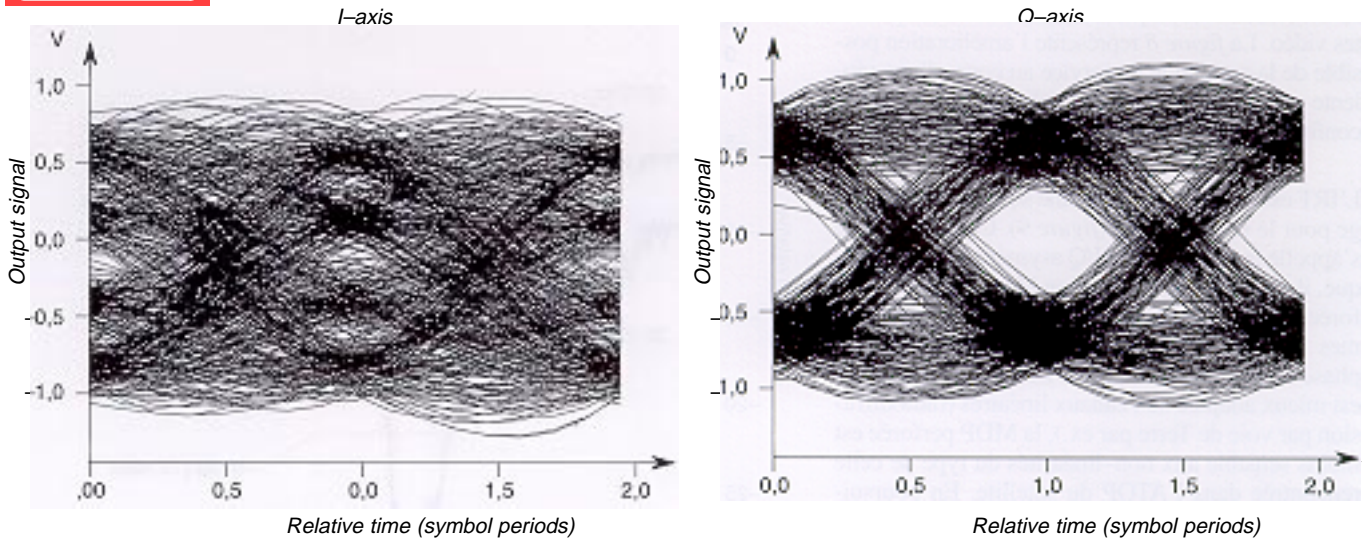
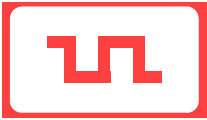

Note the 4-level signal at the in-phase and the 2-level signal at the quadrature-phase output of the demodulator. (Computer simulation for $E_b/N_0 = 12$ dB, roll-off = 0.5, matched square-root raised cosine Nyquist filters).

Figure 10
Example of a demodulated asymmetrical I/Q signal applying eight phase states.

determines the robustness of the transmission. Fine-tuning can be done by varying the forward error-correction (FEC). The summation point corresponds to the RF or orthogonal multiplexing function. For a given modulation scheme, and a given HDTV programme, the configurations (and

thus the bit-rates) of the individual transport streams remain constant. The association of the various programme components with the available layers of modulation can be determined and controlled by the programme provider.

Figure 11
Generation of an HD-SAT signal for three-layered modulation (example shows simulcast approach). The indications of the various modulation forms correspond with those in Figs 7a, 7b and 12.

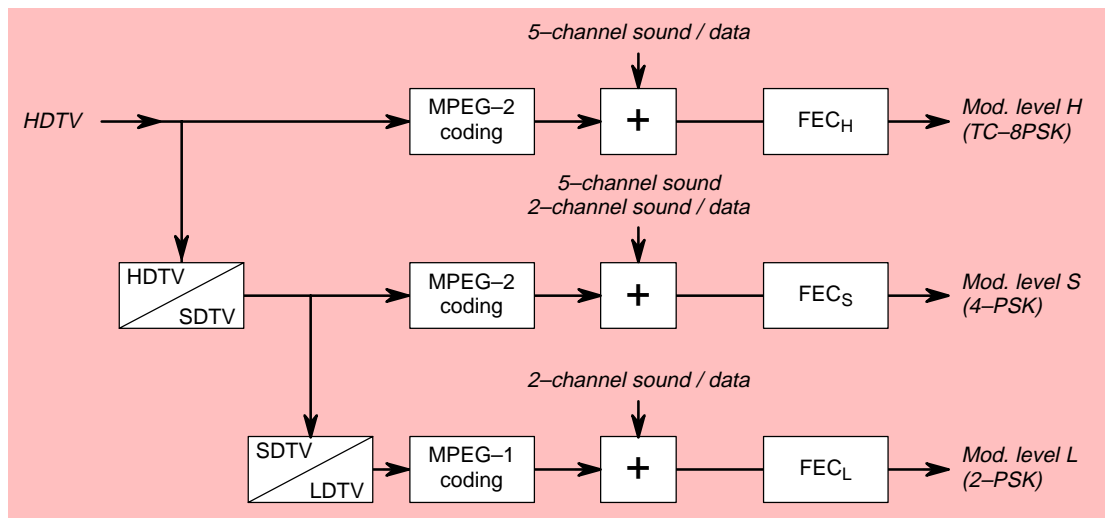
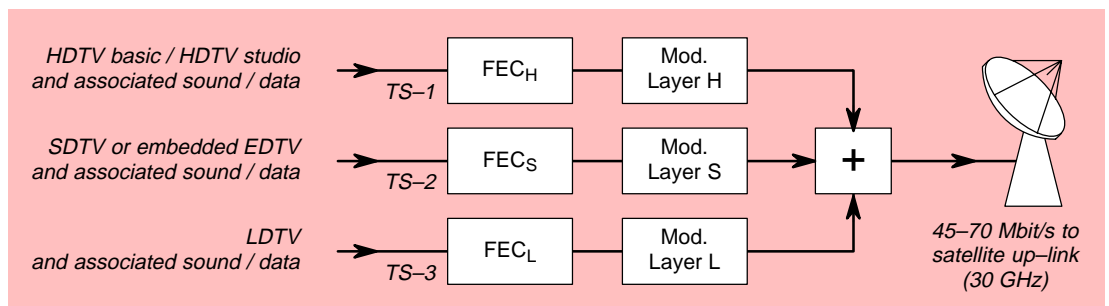

Figure 12
Principle of layered modulation.



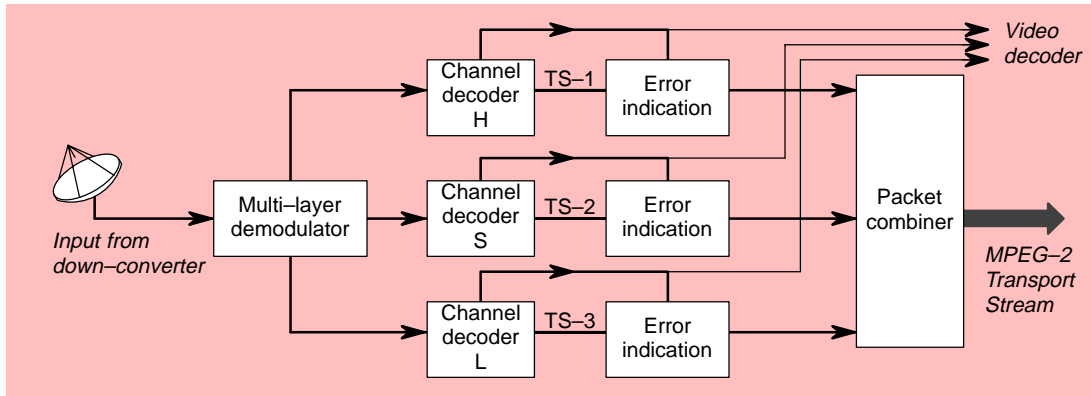

Figure 13
Principle of receiving
an HD-SAT signal with
three modulation
layers.

Fig. 13 shows the principal functions of a multi-layer HD-SAT receiver. After error-correction, each channel decoder regenerates the data packets of its associated transport stream. Un-corrected (residual) errors are signalled in the packet headers and additionally in one of the information tables. HD-SAT is currently investigating whether these measures are sufficient or whether direct signalling of erroneous blocks could be advantageous with a view to applying error concealment techniques in the video (and possibly the audio) decoders. The latest studies by the RAI for hybrid DCT (using unidirectional coding, not bidirectional prediction as in MPEG-2) indicate that surprisingly good results can be achieved by concealing erroneous blocks of pixels up to a BER of about 10-3 [13]. Fig. 14 illustrates the principle of the video decoding of a three-layer HD-SAT signal (hierarchical approach). The nominal service is represented by the HDTV component, and EDTV/SDTV or LDTV are only displayed during more or less strong rain-fades. Of course, the up-converter from, for example, EDTV to HDTV can also be used by other input signals than those provided by the HD-SAT service (common receiver concept).

The investigations concerning the actual choice of the data-rates, and whether or not spatial scalability should be applied, are not yet complete. The

tendency is to code an HDTV signal (about 40 Mbit/s) in simulcast technique and apply spatial scalability only if the quality level of the second layer reaches data-rates of 9 - 10 Mbit/s and therefore enables EDTV. Also, the discussion is not finished as to whether really three layers of modulation are required or whether two layers (e.g. 40 Mbit/s for HDTV and 4 Mbit/s for SDTV) could suffice. The problem lies with the eventual requirements for service continuity and with the display of the SDTV signal that may - in contrast to EDTV - show substantial coding artefacts when up-converted to the HDTV format. Displaying the SDTV signal with reduced size does not seem desirable. Preliminary trials by the BBC show promising results, however. At least for certain sequences, up-conversion of SDVT, and also of LDTV, prove, astonishingly, to give albeit not sharp but quite acceptable pictures. The hardware currently being built will provide further insight into this problem. In any event, by the time of the HD-SAT system presentation in 1995 the CCETT modem will only be available with two layers.

5. Cable and MMDS

For the terrestrial transmission of HDTV, layered modulation (possibly in conjunction with layered picture coding) represents a means to receive and decode the broadcast signal under different receiv-

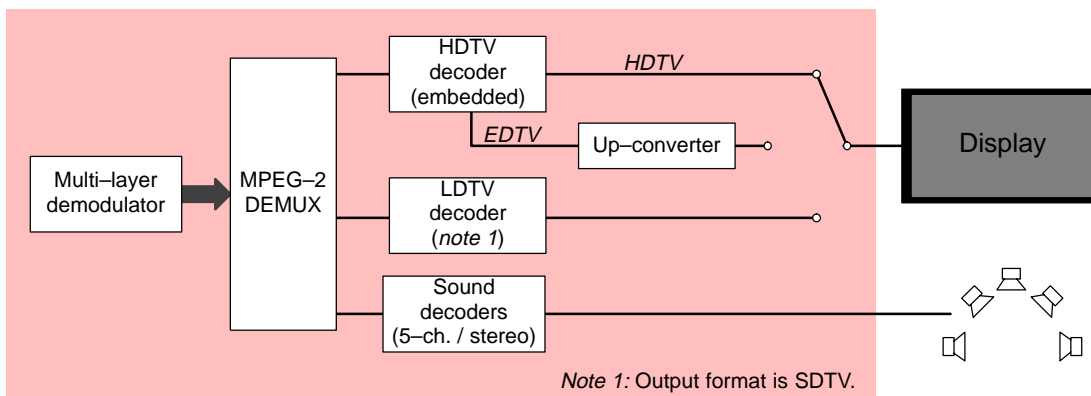
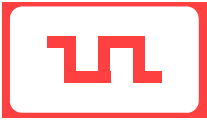

Figure 14
Principle of decoding
a three-layer
HD-SAT signal
(hierarchical
approach).



ing conditions. Whilst the demodulation of the HDTV signal would require a fixed installation with a roof-top antenna, the more robust modulation layers will serve for the portable reception of SDTV with good quality. In contrast to this multi-service scenario for terrestrial broadcasting, HD-SAT is specifically intended for stationary reception of satellite signals; HDTV constitutes the nominal service which will be available most of the time. The sole purpose of EDTV/SDTV or LDTV is to extend the service continuity during periods of precipitation. EDTV (or SDTV) and LDTV represent, in effect, emergency measures and are not necessarily a separate service for reception with especially small parabolic or phased-array antennas. This fact leads to two important conclusions for programme-making and signal distribution:

- In coaxial cable networks and in services provided via MMDS as they exist today (typically at 2.5 GHz), simulcast television signals need not to be carried. They can be discarded, without loss of HDTV quality at the transcoding site (see Fig. 5).³
- The dramaturgy of a programme can be made fully dependent on the creative needs of an HDTV production. Only for some hours per year, will the picture will be displayed in SDTV or LDTV, possibly on a smaller screen size. A hierarchical EDTV component may always be up-converted to full-size HDTV format.

3. The handing-over of simulcast SDTV and LDTV components is not required as cable and MMDS head-ends will be designed to result in an HDTV availability of at least 99.9% of the worst month. For time percentages higher than 99.9% the rain attenuation increases so drastically, following the exponential curve of attenuation versus time percentage, that a hierarchical form of modulation would hardly improve the situation. Layered modulation is the means to allow for individual reception with relatively small antennas.

In its first realization, HD-SAT adopted multi-level VSB/AM for narrow-band transmission via MMDS and coaxial cable networks. 8- or 16-VSB/AM appeared technically simpler and somewhat more robust than the corresponding forms of quadrature modulation, 64-QAM and 256-QAM. In turn, the latter provide, in a given channel, a slightly higher data capacity, because in the case of VSB-AM the vestigial side-band occupies about 500 kHz of additional bandwidth. All high-speed multi-level data transmission systems need correction of the linear distortions caused by filters and, especially important, by signal echoes. For VSB/AM, one (linear) cancellation circuit is sufficient while complex compensation circuits are required for QAM. On the other hand, these complex circuits (for both the I and Q planes of the modulation signal) need only operate at one-half of the speed (half the symbol rate), for a given data-rate [14, 15]. The transmission of 54 Mbit/s within a 12-MHz wide cable channel was successfully demonstrated by the CCETT in November 1993, applying 8-VSB/AM. It is now known, also, that the USA has chosen 8-VSB/AM for the terrestrial broadcasting of HDTV [16].

In Europe, the DVB initiative specified the transmission of 64-QAM in an 8-MHz wide cable channel for a maximum channel bit-rate of about 41 Mbit/s (including the Reed-Solomon baseband FEC). The relevant Draft European Telecommunication Standard was issued in June 1994 [11]. In order to assure system conformity, the HD-SAT consortium agreed in January 1994 to aim also at 64-QAM within an 8-MHz wide channel. However, to accommodate the minimum data-rate of 45 Mbit/s required by HD-SAT, the Nyquist roll-off must be reduced from 15% to 6.7%. The CCETT has taken up this technical challenge and is manufacturing a corresponding HD-SAT cable modem in time for the final system demonstration at Montreux. The IRT will be concentrating on the compensation of short-term echoes. By applying



Mr. Christoph Dosch graduated in telecommunications engineering at the Technical University of Munich and has been with the Institut für Rundfunktechnik since 1976. He is currently Deputy Head of the Broadcasting Service and Transmitter Engineering Department and the IRT coordinator for the HD-SAT project.

In the past, much of his work has been concerned with the various aspects of analogue and digital satellite sound and television broadcasting.

Mr. Dosch is an active participant in the ITU Radiocommunication Sector and in EBU Working Parties R and V. He is Chairman of EBU Sub-group R3 (Satellite broadcasting) and Vice-Chairman of the corresponding ITU-R Working Party 10-11S. Within both the EBU and the ITU-R he has been involved in the standardization of new broadcasting systems and in the preparation and representation of broadcasters' interests in the ITU World Administrative Radio Conferences dealing with satellite broadcasting (WARC-BS 77, WARC-ORB(85)/(88) and WARC-92).



acoustic charge transport (ACT) technology, extremely rapid equalization can be achieved with analogue surface acoustic wave (SAW) filters whose transfer function is controlled digitally. In contrast to all-digital filters, ACT filters can also be used at intermediate frequencies.

In combination with channel equalizers, the QAM signal is equally usable for MMDS emissions. Coded orthogonal frequency-division multiplexing (COFDM) is also being investigated for this purpose.

It is to be noted that a channel equalizer restores the impulse response of the channel in such a way that the best match is achieved between the spectral forming of the incoming signal and the filtering action of the receiving side. In other words, a channel equalizer can act correctly upon signals having different roll-off characteristics. Digital recovery of the carrier phase and of the signal clock enable the demodulation of signals with variable data-rate. (The latter feature is demonstrated by an HD-SAT TC-8PSK modem for the range 45 – 70 Mbit/s.) Combining both properties, cable demodulators can, in principle, be built which operate for various data-rates and roll-off factors.

6. Closing remarks

The HD-SAT consortium is working in close cooperation with standardization bodies such as the ITU

Radiocommunication Sector and the EBU, and is maintaining contact with MPEG, DVB and some ATM Working Groups. In addition to the theoretical studies, a series of devices are being built for system demonstration, tests and field trials. Laboratory prototypes are being presented in a number of workshops and their interconnection is being tested. Some of the milestones in the HD-SAT project which have happened and which are planned are listed below.

The project will be terminated in 1995 with an extensive system demonstration, presumably hosted with the assistance of the EBU at the International Television Symposium in Montreux in June 1995. The emphasis of this demonstration will be on 30/20-GHz satellite transmission applying layered modulation and the subsequent cable transmission using 64-QAM for a 45-Mbit/s data-stream in an 8-MHz channel.

In consultation with the RACE Central Office, the Consortium decided to carry out this demonstration and to stop most of the system developments foreseen for the year 1995 in order to cope with the fact that, unfortunately, after three years of full funding, in the fourth year RACE could only make available about 25% of the requested financial support. More advanced developments in the domain of satellite modems or the auto-adaptive equalization of echo distortions in cable networks

Principal HD-SAT demonstrations and workshops, 1992 – 1995

November 1992	IRT (DBP-T)	Reference satellite demonstration: 30/20 GHz, 140 Mbit/s, 7 and 5-channel sound (DFS Kopernikus)
January 1993	LER/CCETT	COFDM over satellite simulator (not pursued further)
February 1993	RAI (ESA, Telespazio)	Satellite demonstration: 30/20 GHz, 70 Mbit/s, stereo sound (Olympus)
March 1993	Geneva	EBU/HD-SAT Symposium on Digital Satellite Broadcasting
November 1993	CCETT	Cable demonstration: 8-VSB/AM, 54 Mbit/s in 12-MHz wide channel
July 1994	Telettra	HDTV codec: hybrid DCT with improved motion-compensation, 45 Mbit/s
August 1994	CMI/LER/Telettra	MMDS demonstration for digital HDTV
October 1994	CCETT IRT (DBP-T)	HDTV/SDTV modem with graceful degradation (45 and 4 Mbit/s) Variable bit-rate TC-8PSK modem (45-70 Mbit/s)
November 1994	IRT	Echo compensation in coaxial cable using ACT (digital control of analogue surface-wave filter)
December 1994	IRT/BBC (DBP-T) RAI	MPEG-2 HDTV codec (HL-1440@MP, but non-hierarchical), MPEG-2 MUX-DEMUX Printed antenna for feeder in parabolic dish
June 1995	Montreux ITVS	Final system demonstration (satellite, cable and receiving antenna)

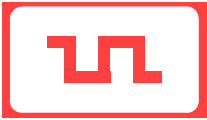

using ACT can therefore not be pursued. Most problematic for the project, however, will be the lack of a video codec for full HDTV studio quality (1920/4:2:2). By the time of the demonstration, the HDTV codec currently built by the IRT will only be operative for the reduced format 1440/4:2:0 (type MPEG-2 "High-1440 at Mean Profile"). Nevertheless, the Consortium hopes that in a follow-up study the necessary development work can be continued.

It has not been possible in this article to illustrate all aspects of the HD-SAT project. The article has not presented the results of the HD-SAT survey on the acceptance of terrestrial and satellite broadcasting of digital TV and HDTV by the service providers and network operators [17, 18] nor the findings concerning the satellite and earth station technology nor the investigations in frequency planning. Also, the achievements for vision coding could not be presented here. It should be mentioned, however, that most of the know-how gained within HD-SAT (by the end of the project it will have produced over 60 "deliverables", that means reports, workshops, demonstrations and prototypes) has importance well beyond the technical development of the 21-GHz frequency range for satellite broadcasting. The results of most of the Work Packages can be used relatively independently of this frequency range. Examples are the HDTV coding, the multi-channel sound transmission, the multiplexing and trans-multiplexing technique, the cable transmission, the interworking with MMDS, the connection to IBCN, the variable bit-rate home receiver, the development of frequency planning techniques, the determination of protection ratios, etc. Even the modulation technique for the satellite path, especially tailored to the relatively difficult propagation conditions in the 21-GHz frequency range, can find applications in other frequency bands. Serving possibly as key for exploiting even higher frequencies for satellite broadcasting (e.g. 40.5 – 42.5 GHz), the concept of graceful degradation may also help tropical countries to open up the 12-GHz frequency range for satellite broadcasting. The modernisation of the WARC-BS-77 Plan figures on the agenda of the next World Radio Conferences. A revision is due in 1997, which shall especially take into account the needs of tropical countries for wide-RF band HDTV (Resolution number 524 of WARC-92).

Developments for the 21-GHz band are continuing. In 1998, Japan will have at their disposal the first test transponder for wide-RF band digital satellite broadcasting in the frequency range 21.4 – 22 GHz (satellite project COMETS). By the end of this century, an ITU planning conference may be held to ensure in the future the equitable but flexible use of the

21.4 – 22 GHz band by the ITU members (Resolution 526 of WARC-92). For this planning conference, technical parameters have to be developed in order to deduce the corresponding regulatory provisions.

Acknowledgement

This contribution reflects the common effort and engagement of all the HD-SAT project partners. The work within the project is characterised by a positive and objective-oriented collaboration in an open and friendly atmosphere. Many thanks are also due to the BBC and the EBU, who contribute to the project without financial support, and to the project's sponsors, the Deutsche Bundespost Telekom, the European Space Agency and the Italian Telespazio for allowing access to their 30/20GHz satellites and earth stations.

From 1986 to 1992 the IRT has carried out two basic studies on HDTV satellite broadcasting in the 20-GHz frequency range under contracts with the German Ministry for Research and Technology. The IRT is most thankful for this support as it laid the basis for involvement in the subsequent HD-SAT project. The work reported here on HD-SAT is sponsored by the Commission of the European Union within the framework of RACE. The responsibility for the content of this article lies, however, with the author.

Bibliography

- [1] **Advanced techniques for satellite broadcasting of digital HDTV at frequencies around 20 GHz. Collected papers on concepts for wide-band digital HDTV – satellite broadcasting into the 21st century** European Broadcasting Union, Geneva, February 1992.
- [2] Dosch, Ch.: **Digital broadcasting of studio-quality HDTV by satellite in the 21-GHz frequency range and by coaxial cable networks** EBU Technical Review, No. 256 (Summer 1993), pp. 45–53.
- [3] Cominetti, M., Dosch, Ch., Kozamernik, F., Tanton, N., Oest, J., Bourguignat, E.: **EBU demonstrations of wide-band digital HDTV satellite broadcasting technologies at WARC-92** EBU Technical Review, No. 252 (Summer 1992) pp. 26–44.
- [4] Noll, P., Stoll, G.: **ISO/MPEG: A generic concept for high-quality audio coding of 2-channel and 5+1 multichannel sound** Proceedings, International Workshop on HDTV, Ottawa, October 1993, Vol 1.



- [5] Reimers, U.: **European perspectives on digital television broadcasting – Conclusions of the Working Group on Digital Television** EBU Technical Review No. 256 (Summer 1993), pp. 3–8.
- [6] Wood, D.: **European perspectives on digital television broadcasting – Quality objectives and prospects for commonality** EBU Technical Review No. 256 (Summer 1993), pp. 9–15.
- [7] ISO/IEC: **Information Technology – Generic coding of moving pictures and associated audio** Recommendation H.262; ISO/IEC 13818–2, Draft International Standard, 25 March 1994.
- [8] Wilkens, H.: **System requirements and introduction strategies for future digital broadcast systems** Proceedings, Europa Telecom'92 Symposium, Budapest, October 1992.
- [9] ISO/IEC JTC1/SC29/WG11 Doc. N0721: **Information Technology – Generic Coding of Moving Pictures and Associated Audio – MPEG–2 Systems** Recommendation H222.0; ISO/IEC 13818–1 Draft International Standard, 13 June 1994
- [10] Draft European Telecommunication Standard prETS 300 421: **Digital broadcasting system for television, sound and data services: Part 6 – Channel coding and modulation for 11/12 GHz services** ETSI, Sophia Antipolis, June 1994.
- [11] Draft European Telecommunication Standard prETS 300 429: **Digital broadcasting system for television, sound and data services: Framing structure channel coding and modulation for CATV cable and SMATV distribution** ETSI, Sophia Antipolis, June 1994.
- [12] Palicot, J., Veillard, J.: **Possible channel coding and modulation system for the satellite broadcasting of a high–definition television signal** Signal Processing: Image Communication 5 (1993), pp. 463–471.
- [13] Stroppiana, M., Zenoni, N.: **Codifica del segnale televisivo numerico – mascheramento degli errori residui di canale** (Digital television signal coding – concealment of residual channel errors) Eletttronica e telecomunicazioni No. 2, 1993, pp. 61–70.
- [14] **HD–SAT (R2075): Demodulation (Cable) – Theoretical studies** Reference No. R2075 CET DCS DS P 223–A2, Brussels, October 1993
- [15] Schöps, G.: **Bandbreiteneffiziente Modulationsverfahren für die Kabelübertragung von Digital–HDTV** (Bandwidth–efficient modulation techniques for the cable transmission of digital HDTV) Rundfunktechnische Mitteilungen, Vol. 38 (1994) No. 2, pp. 60–67.
- [16] Hopkins, R.: **Digital terrestrial HDTV for North America – The Grand Alliance HDTV system** EBU Technical Review, No. 260 (Summer 1994), pp. 36–50.
- [17] O'Neill, J.: **Terrestrial broadcasters and digital television** World Broadcast News, March 1994, pp. 106–108.
- [18] **Satellite digital transmission – The first bytes** Cable and satellite Europe, February 1994, pp. 48–50.

EBU List of LF/MF broadcasting stations



The 47th annual edition of the **EBU List of LF/MF broadcasting stations** will be published during August 1994. The document gives details of 1859 transmitters in service in the European Broadcasting Area on 1st May 1994, according to official sources and observations at the EBU Receiving and Measuring Station (CEM) at Jurbise, Belgium. The document also gives details of the 3357 stations in these frequency bands which are listed in the Geneva Plan (1975) and the ITU's International Frequency List.

The List is typeset directly from the EBU computer files. It contains a classification by frequency of all transmitters in the spectrum, a separate classification, also in order of frequency, for each country, and an alphabetical index. The following information is given for each transmitter: geographical coordinates, frequency (to the nearest kilohertz), power, direction of maximum radiation and antenna diagram. Additional information is drawn from the Geneva Plan, including in particular the transmission times.

Orders for the **EBU List of LF/MF broadcasting stations** should be sent to EBU Publications, CP 67, CH–1218 Grand–Saconnex (Geneva), Switzerland (Fax: +41 22 717 2481). Price category “D” (70 Swiss francs, including surface mail).